

# CAPITAL MARKETS PRESENTATION 31 MARCH 2011, LONDON

*Performing At A New Level*

Mark Robertshaw

# Agenda

• Introduction and Group financial goals to 2013	Mark Robertshaw
• Ceramics: major profit drivers	Andrew Hosty, Mark Moore, Jim McRickard, Ian Robb
• Engineered Materials: major profit drivers	Don Klas, Tom Odle, Mike Murray
• ROCE and linkage to long-term incentive plans	Kevin Dangerfield
• Wrap up and Q&A	Mark Robertshaw

# Morgan Crucible is a world leader in advanced materials ...

- Differentiated and innovative products sold into technically demanding applications
- A high proportion of the business designed in specifically for the individual customer
- Leading global market positions in the majority of our businesses
- Premium pricing with positive price pass through relative to input costs

# Morgan has the number one market position in the majority of our business

## Morgan Ceramics c£600m revenue: main products



Fibre  
£200m



Engineered  
Ceramics  
£120m



IFB /  
Castables  
£100m



Braze Alloys  
£40m



Ceramic  
Cores  
£40m



Assemblies  
£40m



Electrical  
Carbon  
£130m



Soldier  
Survivability  
£130m



Seals &  
Bearings  
£60m



MMS  
£40m



High  
Temperature  
£12m

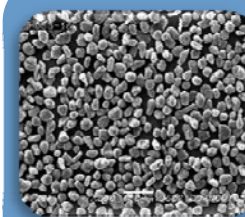

Lithium Ion  
£5m

## Morgan Engineered Materials c£400m revenue : main products

Approximate 2010 revenue

# Financial ambitions by 2013

- Double Group underlying PBT\* from £75.7 million to c.£150 million
- Mid-teen underlying operating profit margins
- Improve Operating ROCE from c.25% in 2010 to c.35% by 2013

\*Underlying PBT is defined as operating profit before amortisation, less net financing costs

# Our ambition is to double underlying PBT

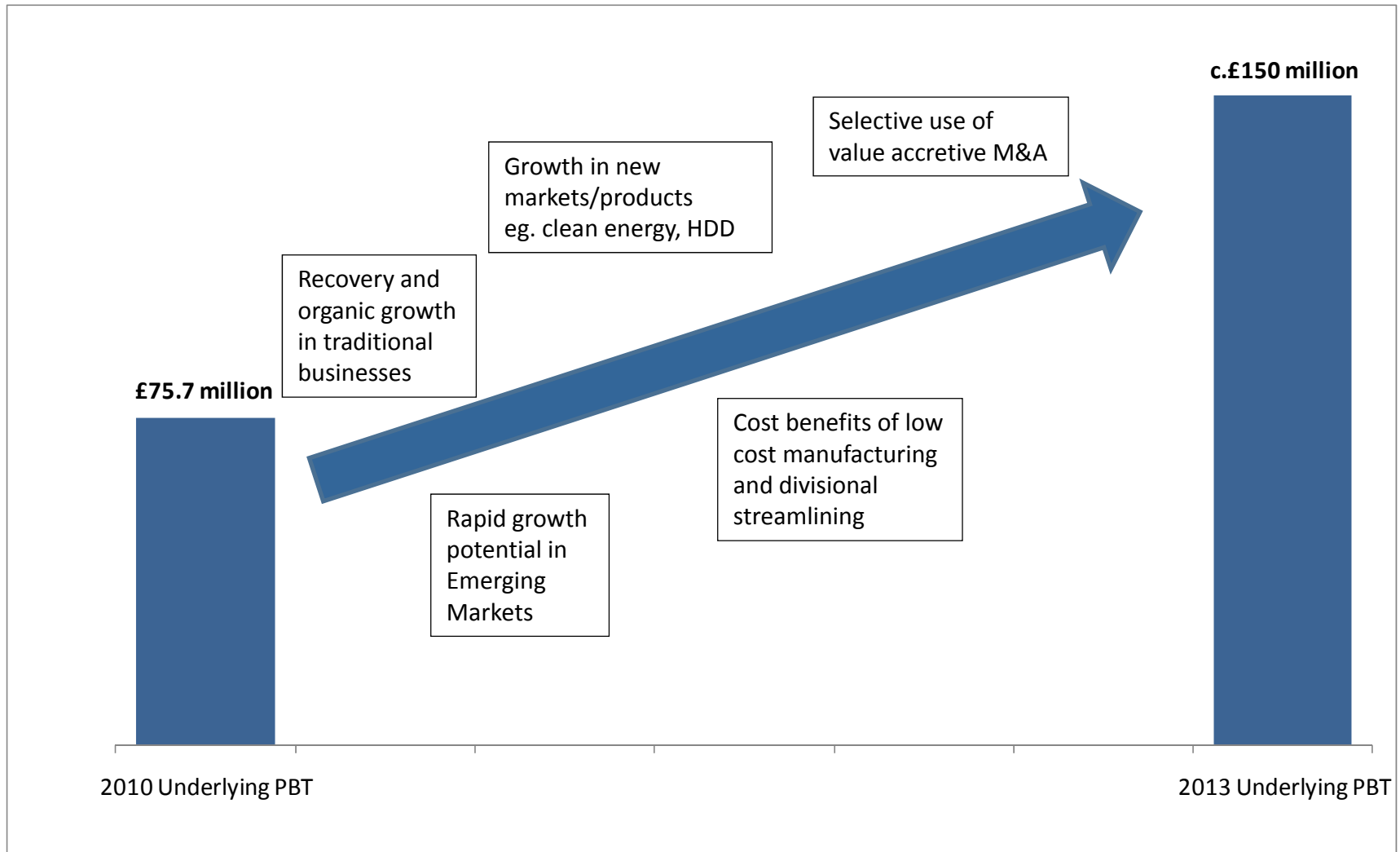

# Recovery and organic growth potential in traditional businesses

Group Sales by Destination (excl NPA)

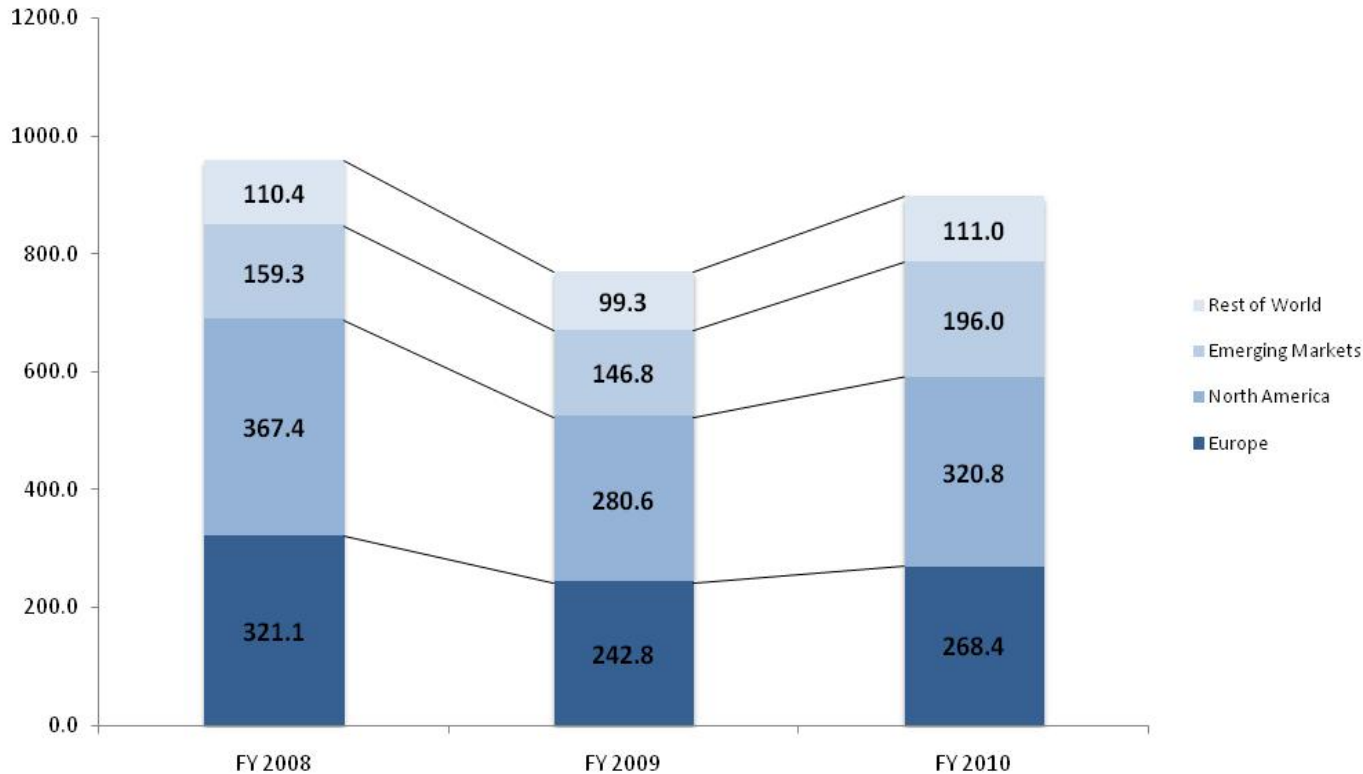

Emerging Markets includes: China, India, Latin America, Russia, Turkey and Middle East  
Rest of World includes: Japan, Korea, Australia, South Africa

All at 2010 actual rates

- Western world revenue picked up somewhat in 2010 but with further recovery potential still to go
- Strong growth in Emerging Markets with constant currency revenue up over 33% in 2010 vs 2009

# Further later cycle recovery to come through in Europe and North America

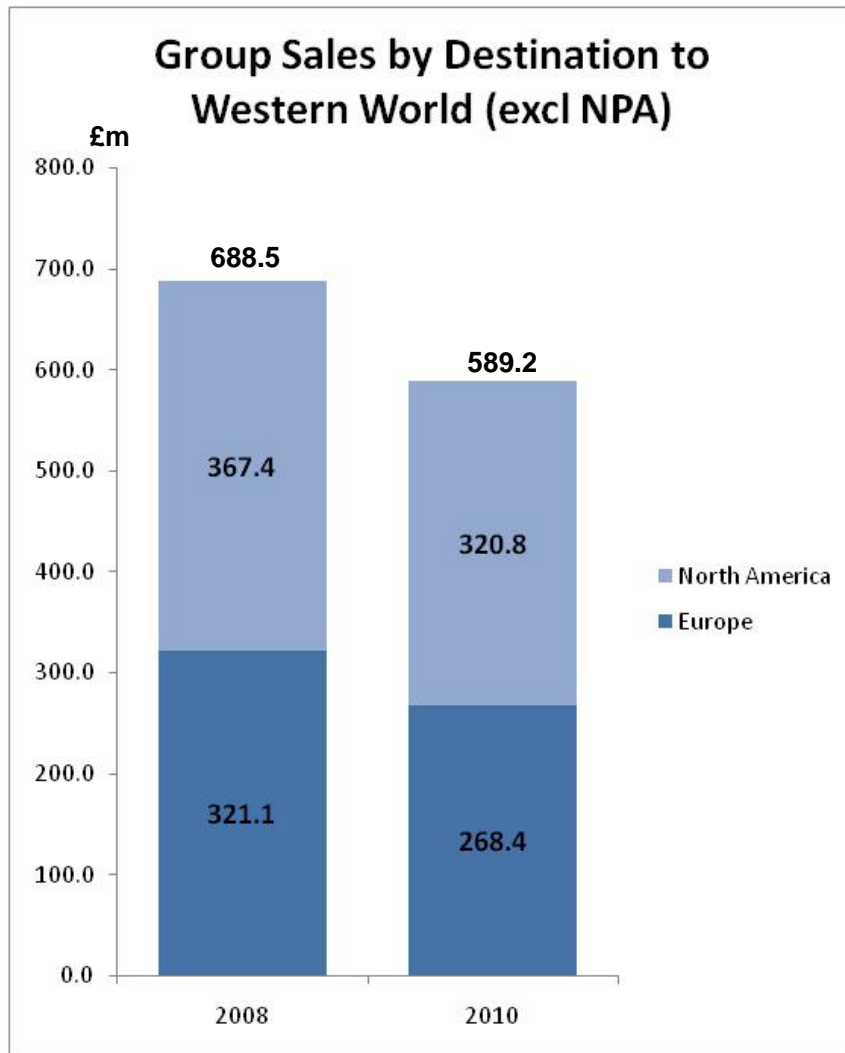

All at 2010 actual rates

- US and European demand continuing to recover with the US coming through slightly earlier; European pick-up led by Germany
- Body Armour revenues in the US in 2010 c.£25m lower than in 2008 reflecting lower market demand levels
- Example areas of later cycle recovery potential
  - Thermal Ceramics project and large capex related business
  - Electrical and Seal & Bearing products in AM&T
  - Industrial Gas Turbine business



# Significant opportunities for further rapid growth in dynamic economies

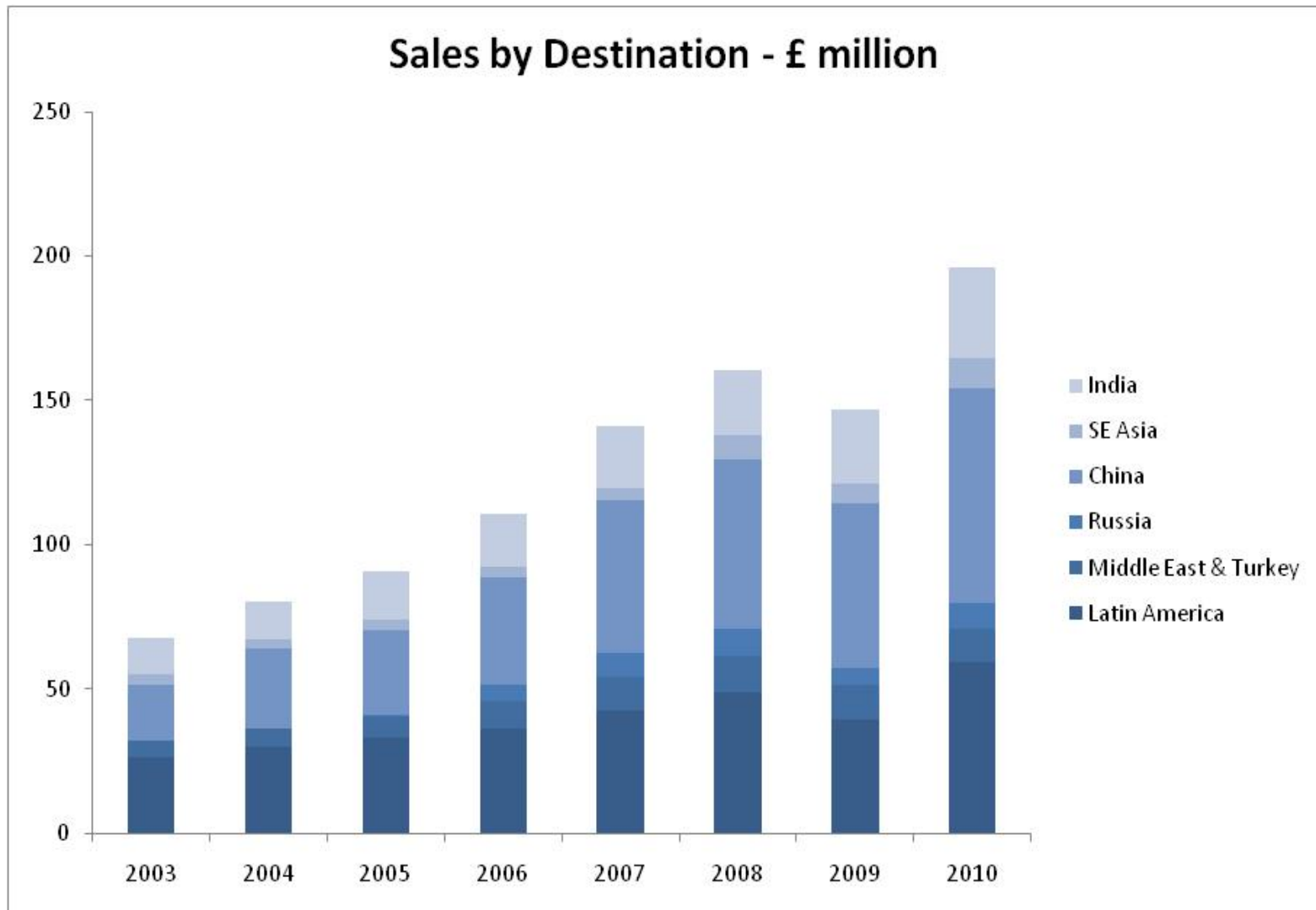

# Our Emerging Markets business is very well aligned to the key areas of economic growth

2010 Emerging Markets Revenue - £196 million

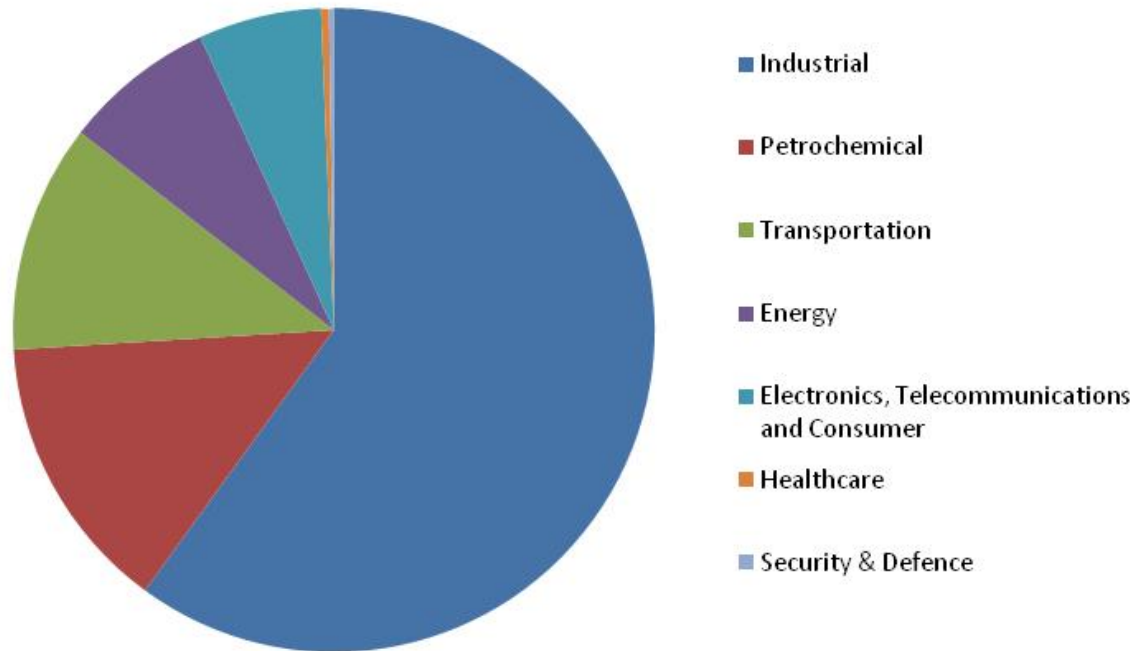

- >90% of Group revenues to Emerging Markets are to the Industrial, Petrochemical, Transportation and Energy sectors
- Strong underlying growth trends in these markets driven by ongoing rapid industrialisation and development of Emerging Market economies
- Potential opportunities in more sophisticated end-markets going forward e.g. Healthcare, Aerospace

# Looking to the future, the latest China 5 year plan plays well to our advanced materials capabilities

## Seven key areas

- |   |   |
|---|---|
| 1 | ■ New energy <ul style="list-style-type: none"><li>– Nuclear, wind and solar</li></ul>  |
| 2 | ■ Energy conservation and environmental protection <ul style="list-style-type: none"><li>– Energy reduction targets</li></ul> |
| 3 | ■ Clean energy vehicles   |
| 4 | ■ High-end equipment manufacturing <ul style="list-style-type: none"><li>– Aerospace and telecom equipment</li></ul>          |
| 5 | ■ Biotechnology <ul style="list-style-type: none"><li>– Drugs and medical devices</li></ul>                                   |
| 6 | ■ New materials <ul style="list-style-type: none"><li>– Rare earths, high-end semiconductors</li></ul>                        |
| 7 | ■ New IT <ul style="list-style-type: none"><li>– Networking infrastructure</li></ul>  |

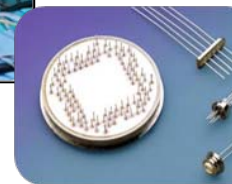
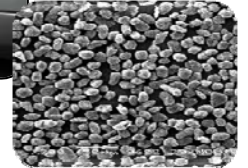
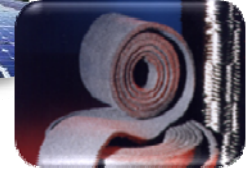
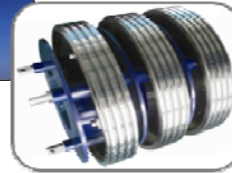

# Exciting domestic growth potential in emerging markets but also more opportunities for low cost

2010 TEC Cost per Employee - £k

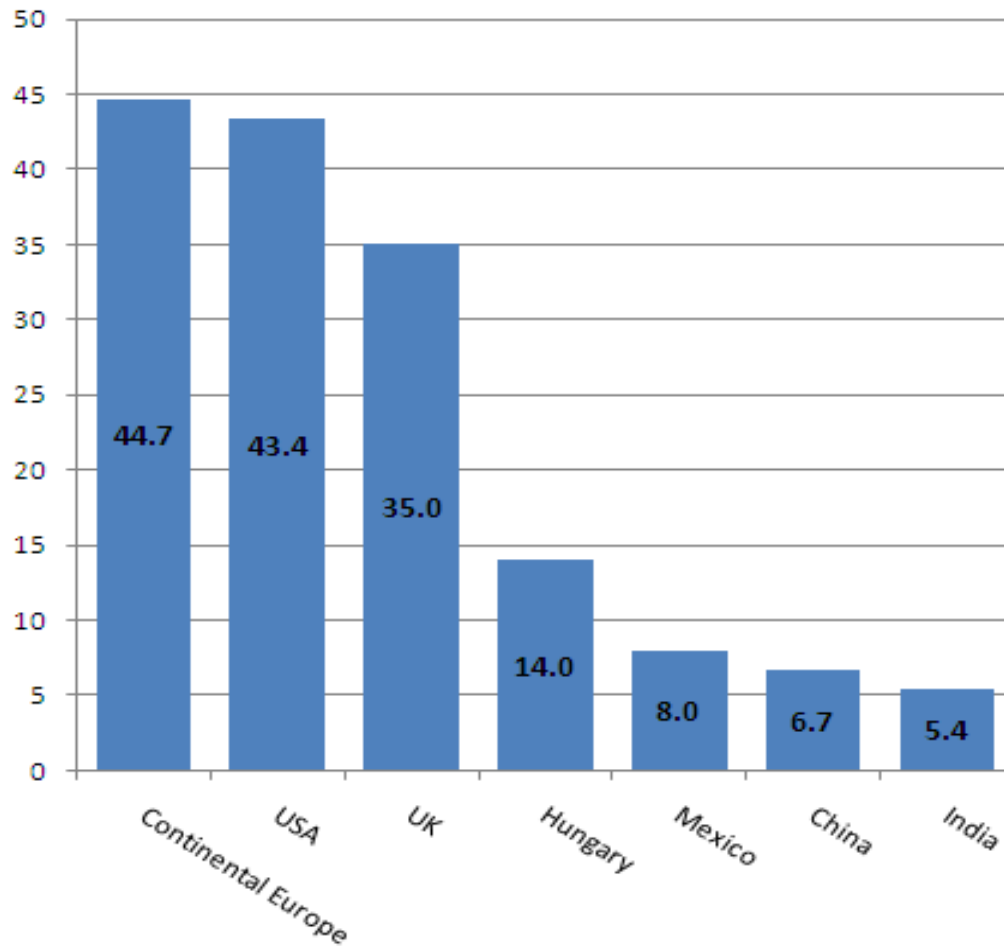

- Total employment costs in low cost countries (LCCs) are up to 7 to 9 times lower per head than in the Western world
- More opportunities to use LCCs to serve Western world demand e.g.
  - Mexico for the US
  - Hungary for Western Europe

# As our business grows, we are disproportionately adding headcount into lower cost countries

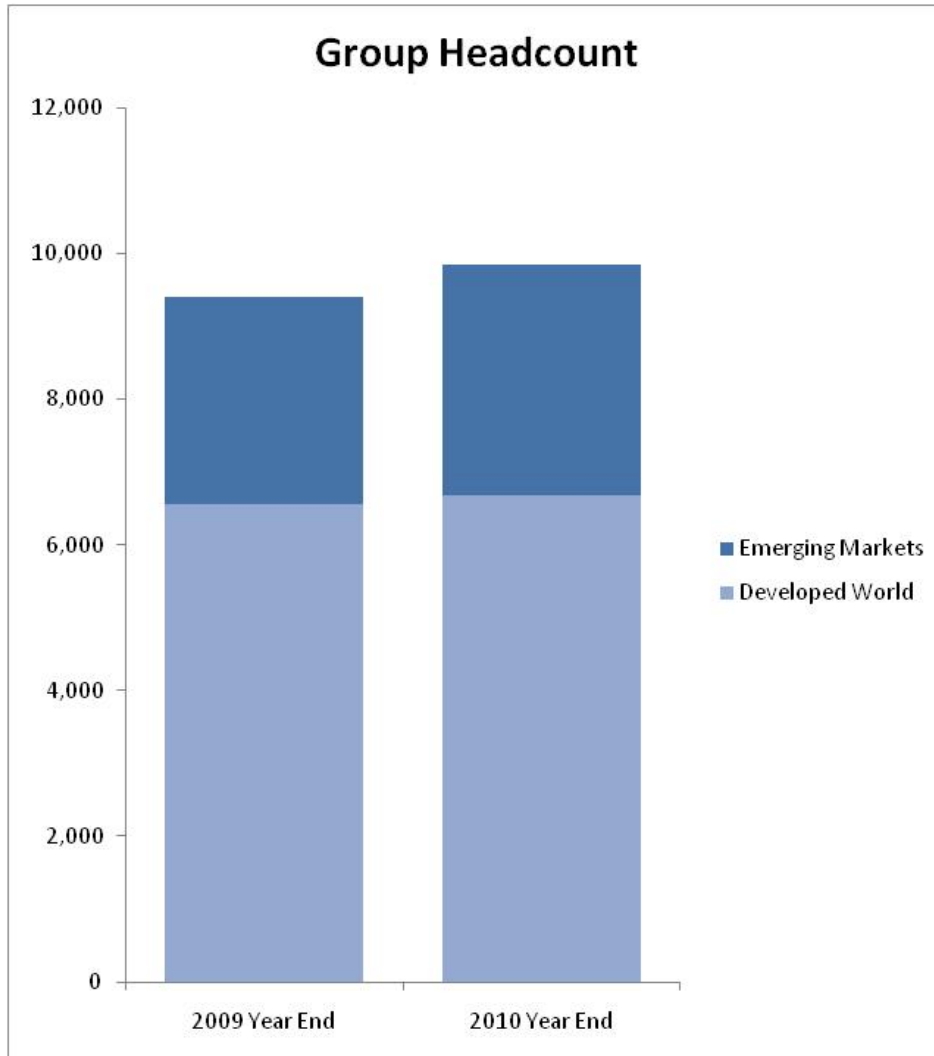

- Group revenues grew over 7% in 2010 with headcount increasing only 4.7%
  - Headcount increase of 10.7% in Emerging Markets....
  - ...and only 2.1% in the Developed World through continued migration of our labour towards LCCs
- Still further scope through our operational excellence programmes to improve LCC productivity levels up to Western world standards

# Margin improvement potential across all our regions – Europe in particular

## 2010 Site Underlying Operating Profit Margin\*

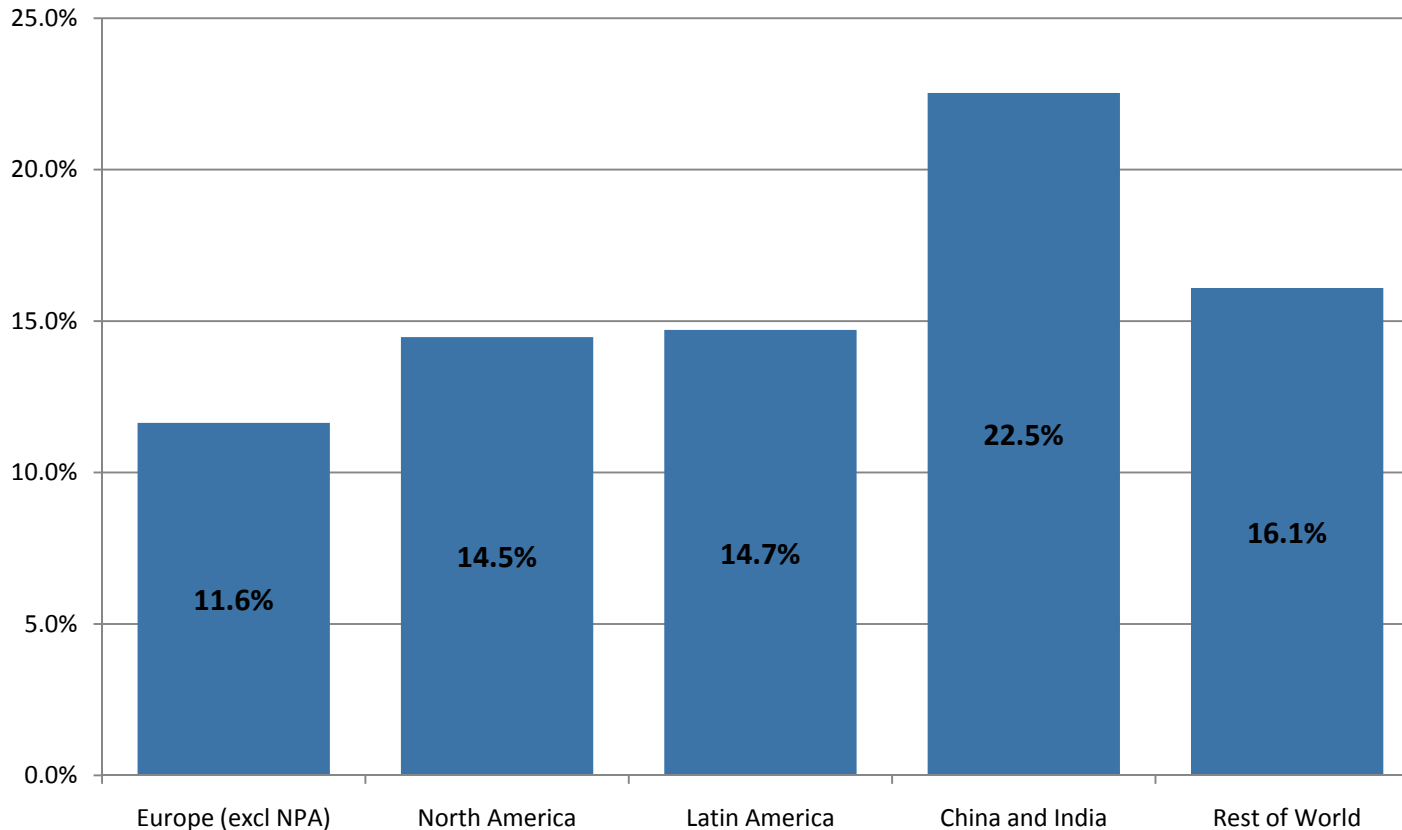

- Technical resource is predominantly in the developed world along with many of the major materials plants
- There is scope to improve margins worldwide, particularly in Europe for Thermal and AM&T

\* Excludes Head Office & GBU overheads and NP Aerospace

# Even with higher inflation; absolute labour cost differential of LCCs growing not shrinking

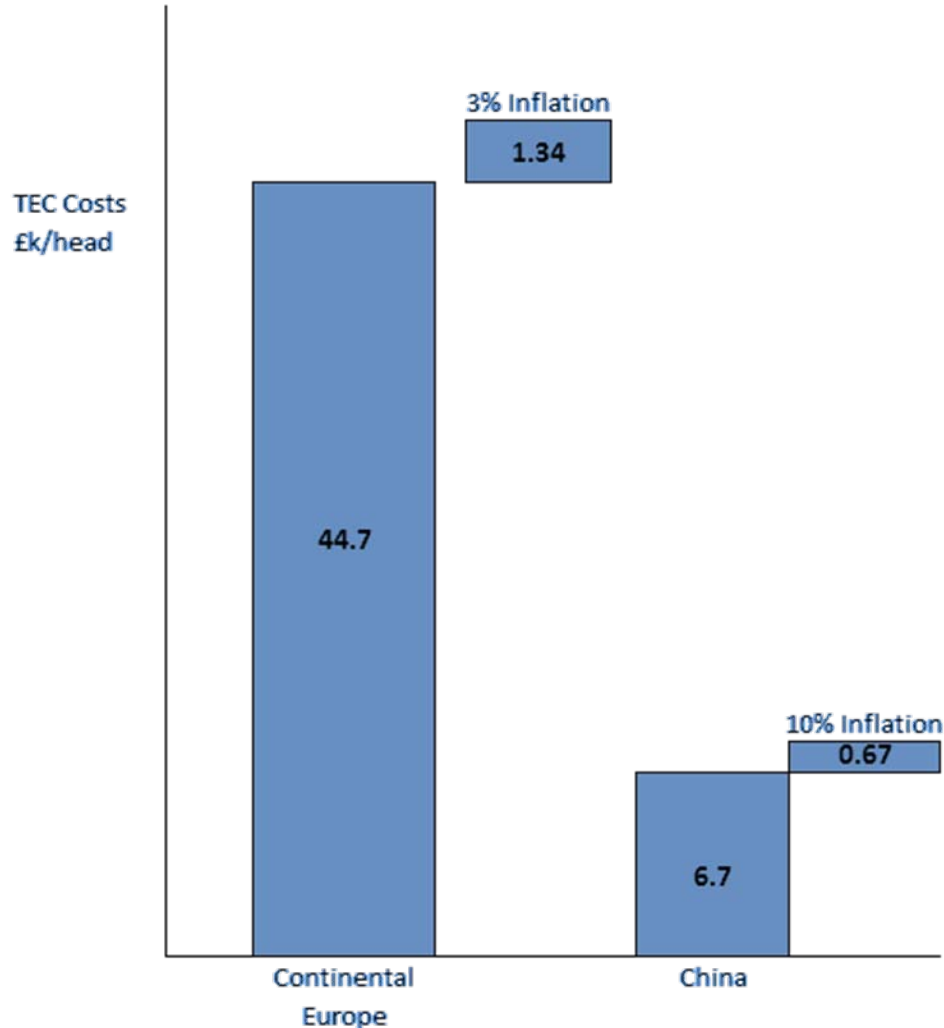

- If total employment costs grow at 3% in the Western world and 10% in China, the relative differential cost per head actually increases rather than narrows
- Still attractive to migrate labour from Western Europe and the US to LCCs

# Continued focus on positive price pass through

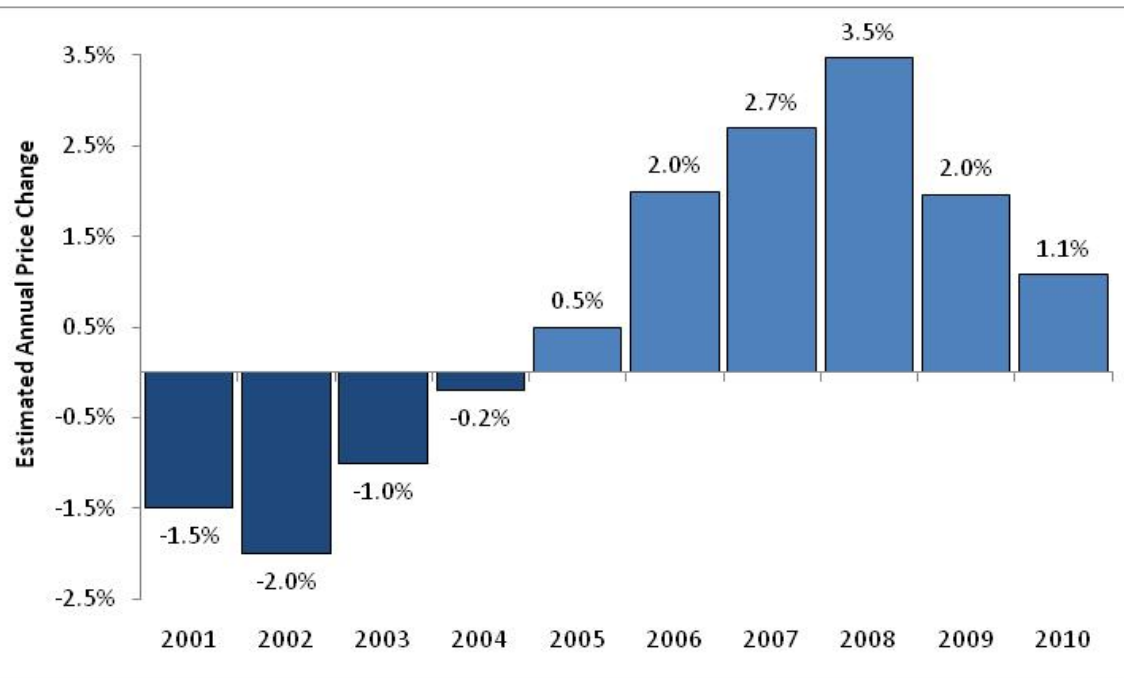

- Differentiated advanced materials solutions sold into technically demanding applications
- Global #1 and #2 market positions in the vast majority of our businesses
- Positive price pass through achieved year-in year-out over the last several years even through the worst industrial downturn in decades
- We expect to continue to deliver this positive price pass through going forward



# Our ambition is to double underlying PBT

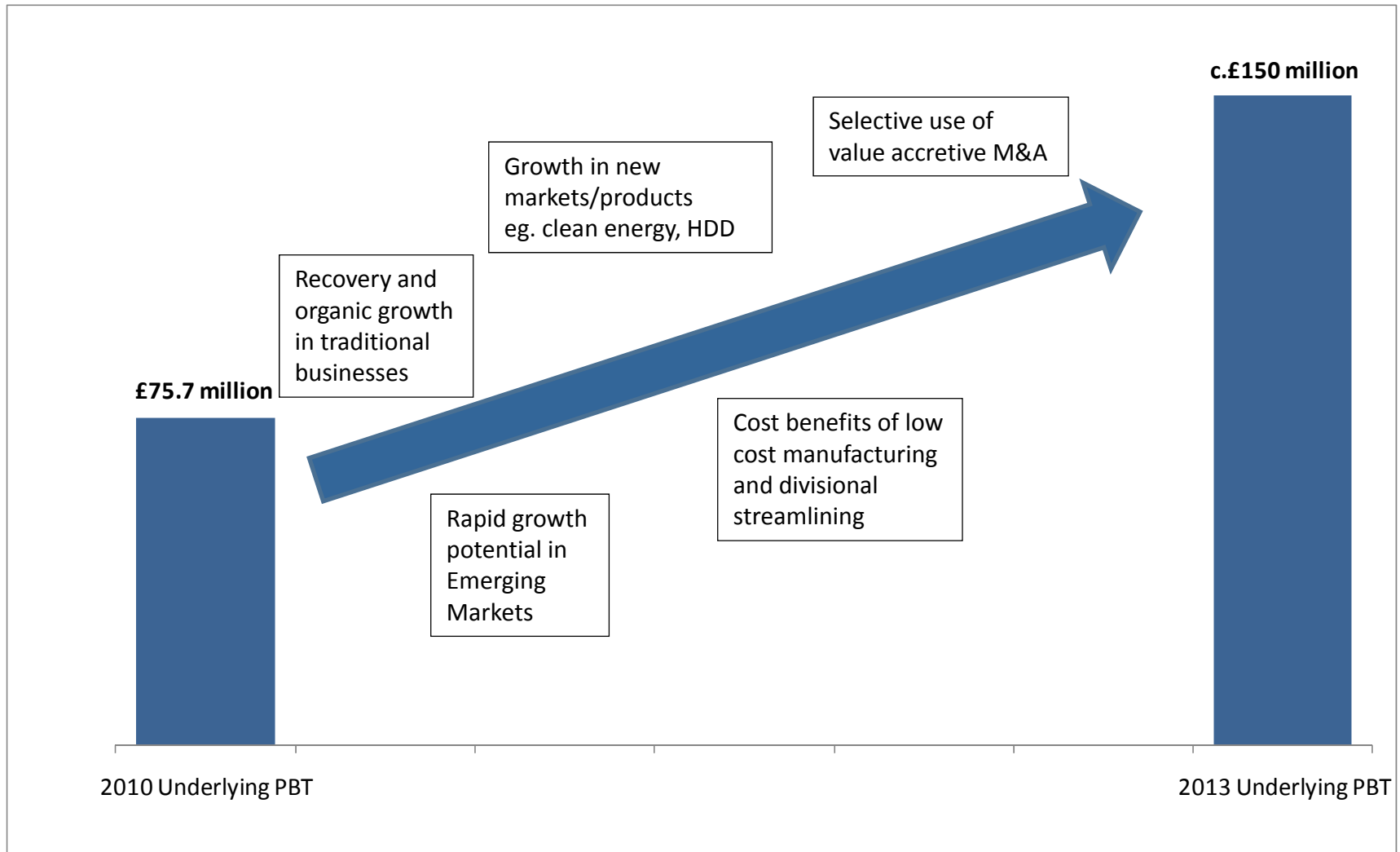

# CAPITAL MARKETS PRESENTATION 31 MARCH 2011, LONDON

*Morgan Ceramics*

Andrew Hosty

# Agenda

- Overview of Morgan Ceramics
- 2010 results
- Project Concord – Mark Moore
- Superwool Strategy – Mark Moore
- Growth plans – Jim McRickard & Ian Robb
- Summary & closing remarks

# Morgan Ceramics brings together the best of the Technical & Thermal Ceramics businesses

- Morgan Ceramics uses competences in material science and applications engineering to manufacture custom products for demanding environments
- We supply customer-specific, applications-engineered industrial products manufactured from advanced materials including structural ceramic, electro-ceramic and precious metals
- We provide provides thermal management solutions for high-temperature applications which benefit technically, financially and environmentally from optimised energy and emissions control



# Unparalleled global reach with significant operational presence in the major markets of the world

## Morgan Ceramics Division



# Why Ceramics...?

The material of choice in demanding applications, that clearly outperforms alternatives, offering (for example):

- Resistance to extremes of temperature
- Stability in harsh environments
- High stiffness to weight ratio
- High voltage insulation
- Chemical resistance
- Vacuum integrity
- Biocompatibility
- Wear resistance

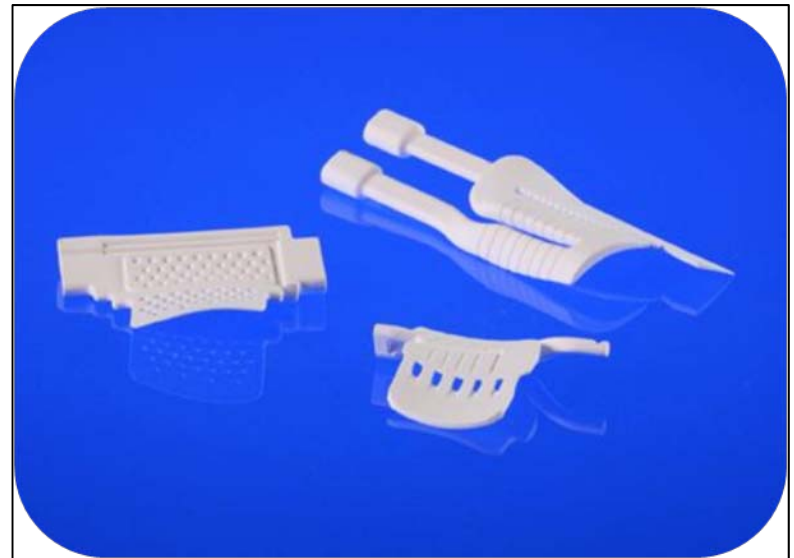

# A broad product portfolio with the majority made to customer specific requirements

## Engineered ceramics



## Fibre Products



## IFB & Monolithics



## Metallised ceramics



## Diamond coating



## Braze alloys

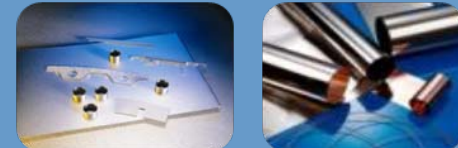

## Assemblies



# Supplying growth markets where we differentiate our product offering

- Electronics

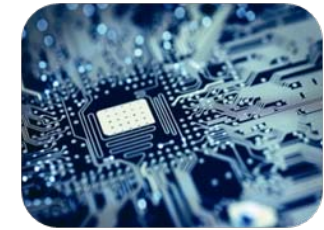

- Energy

- Healthcare

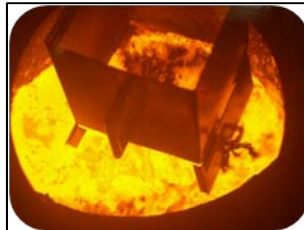

- Industrial

- Petrochemical

- Security & Defence

- Transportation





# Involved in everyday technology



*Did you know?*

Our ceramic / metal assemblies are used in aircraft fire suppression systems?



*Did you know?*

GBC Materials produces over 1 billion alumina components per year for the micro-electronics industry?



*Did you know?*

Alberox feed through assemblies are used in jet engine sensor devices?



*Did you know?*

Diamonex coatings help keep IR optics from scratching in desert sand conditions?



*Did you know?*

We made a key component in the world's fastest colour inkjet printer using ceramic injection moulding?



*Did you know?*

Morgan's piezo ceramic is the key to many parents first view of unborn babies using ultrasound?



*Did you know?*

The TV images of the 2008 Olympic games were broadcast with the aid of our ceramics?



*Did you know?*

Our piezoelectric blood pressure sensors provide fast, accurate ultrasensitive readings?

# Involved in everyday technology



*Did you know?*

Our ceramic hip joints give people their mobility back and with it, their quality of life?



*Did you know?*

Every Boeing 777 is fitted with 52 of Morgan's ultrasonic fuel level sensors?



*Did you know?*

Our injection moulded Zirconia components are used in dental implants?



*Did you know?*

Wesgo's metal brazing alloys set the standard for use in many of the world's jet engines



*Did you know?*

Our precision rod assemblies help with drug testing and development?



*Did you know?*

Our lightweight body armour is so tough that it stops up to three direct hits?



*Did you know?*

Alberox assemblies are used in undersea repeaters for Fiber Optic Cable Communication?

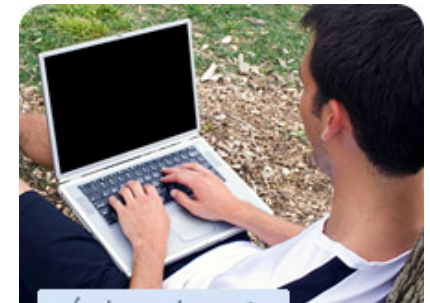

*Did you know?*

GBC Materials' components are key to reducing unwanted noise in electronic devices?

# Working closely with our customers in order to provide optimised solutions

- Extensive range of materials
- Applications Engineers work with customers to establish operating conditions and design constraints
- Materials knowledge and extensive understanding of our manufacturing capabilities combined to create an optimal design for prototypes
- Prototypes are manufactured, trialed and tested
- Depending on the results, design iterations may then take place until the customer's expectations are fully met

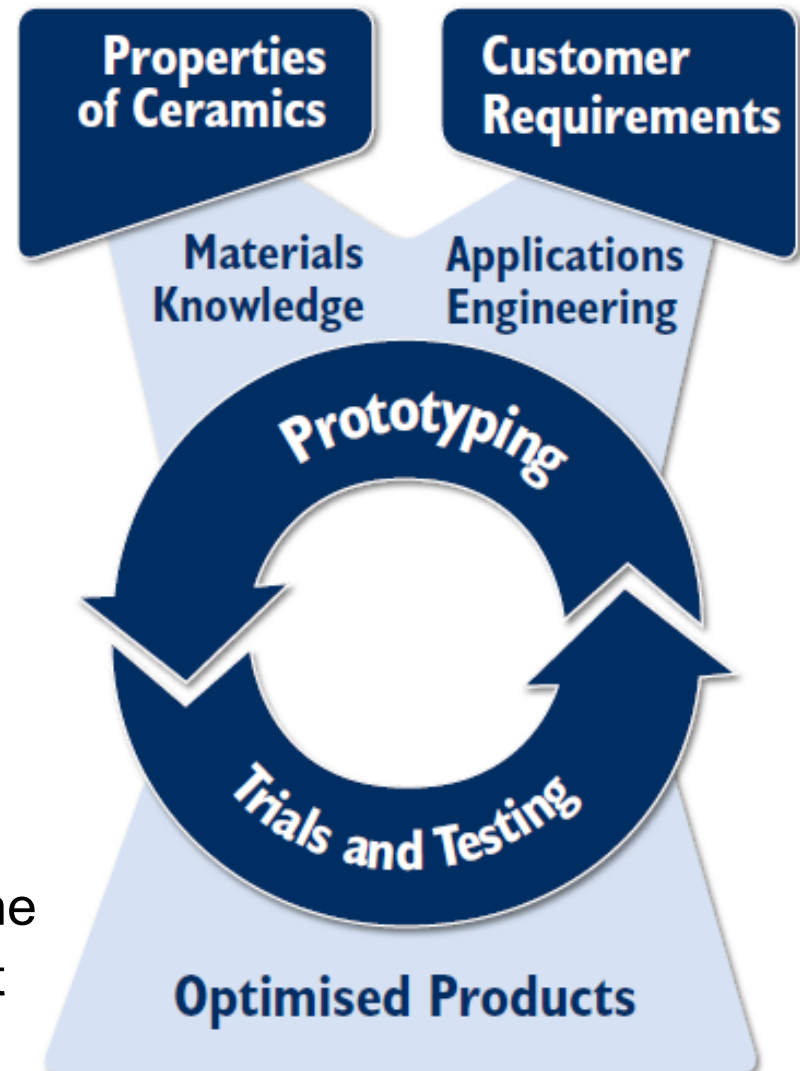

# The Division is managed by a global Executive Team

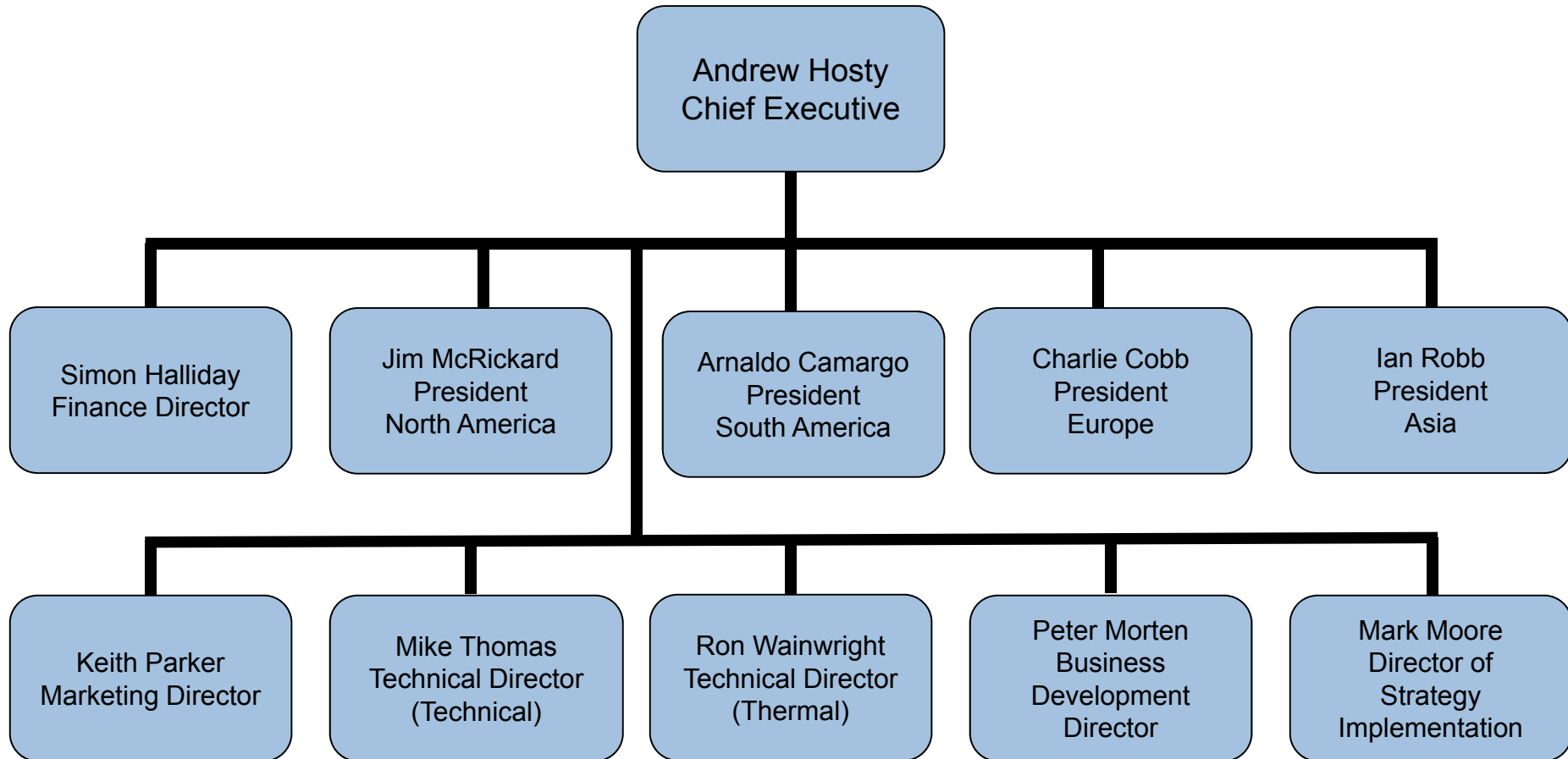

# Market dynamics vary by geography

## The West:

- We are focussed on advanced technologies in higher margin markets where we are differentiated and see better than GDP growth

## Emerging Markets:

- High-tech opportunities exist for our leading technologies
- Our growing business provides the foundation for developing the world's leading advanced materials company
- Industrialisation leads to opportunities for our mature technologies, extending their lives in high growth economies

# We estimate our global addressed market to be circa £3.9bn

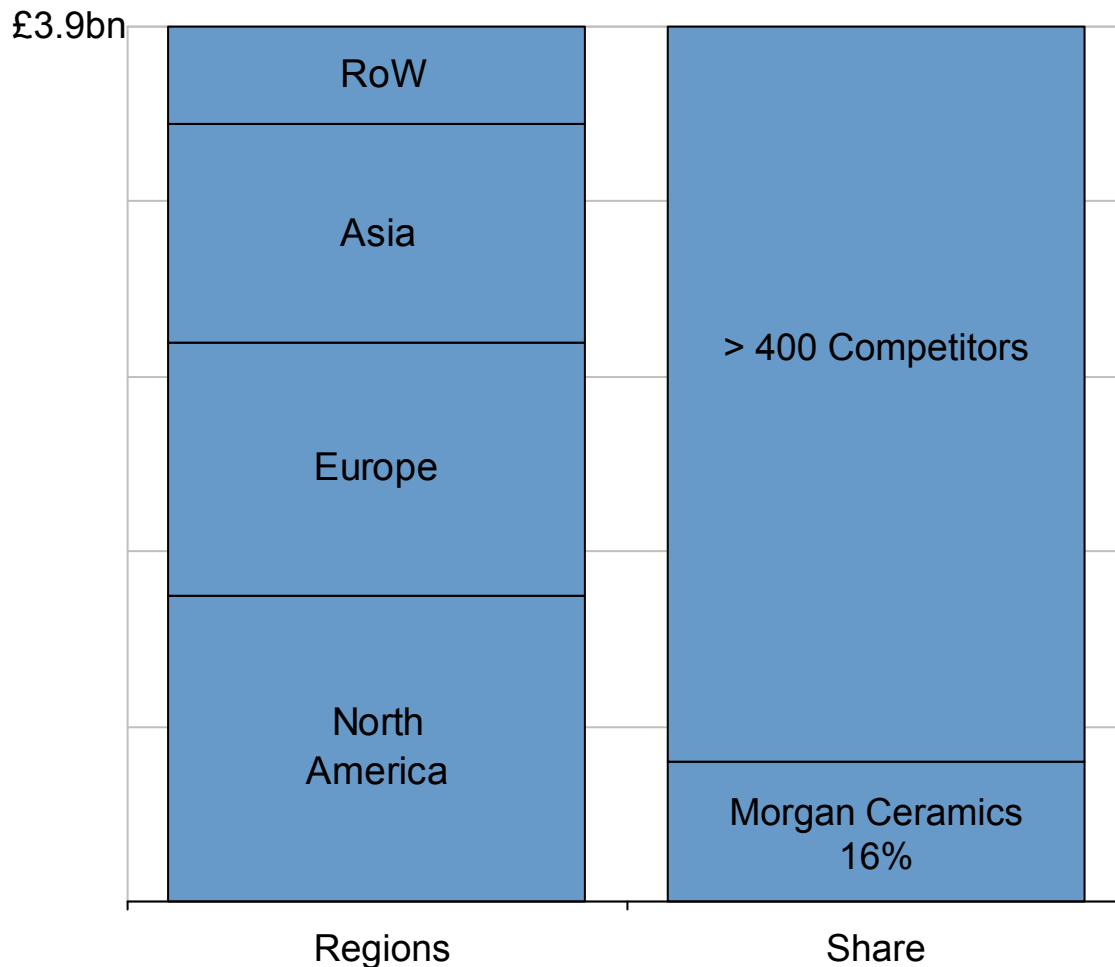

Morgan Ceramics is a circa £600m business operating within an addressed market which is growing faster than GDP

With a 16% overall market share there is significant room for growth

Our market based focus drives good underlying earnings growth

Sources: Global Industry Analysts; Advanced Ceramics Report May 2009 / Marketsandmarkets; Global High Temperature Insulation market report / Internal estimates

# Agenda

- Overview of Morgan Ceramics
- 2010 results
- Project Concord – Mark Moore
- Superwool Strategy – Mark Moore
- Growth plans – Jim McRickard & Ian Robb
- Summary & closing remarks

# Strong progress in revenue, profit and margins

£M	Revenue		EBITA pre-restructuring & one-off items		Profit margins %	
	<u>FY10</u>	<u>FY09</u>	<u>FY10</u>	<u>FY09</u>	<u>FY10</u>	<u>FY09</u>
	Technical Ceramics	250.1	206.0	34.0	25.1	13.6%
Thermal Ceramics	359.0	315.1	34.8	26.7	9.7%	8.5%
<b>Ceramics</b>	<b>609.1</b>	<b>521.1</b>	<b>68.8</b>	<b>51.8</b>	<b>11.3%</b>	<b>9.9%</b>

- Ceramics Division revenue increased c.17% with strong year-on-year growth from both Technical and Thermal Ceramics
- EBITA increased c.33% driving operating margin to 11.3%

All at reported rates



# Ceramics: key value drivers in 2011 & beyond

	2010 Position	Future prospects
Organic growth from targeting markets with > GDP growth drivers	Successful market positioning in Technical allowed strong growth	++
Emerging markets growth strategy	Strong Thermal base in Asia , and LatAm offers leverage for Technical	+++
Roll out of extended Superwool range	Superwool product range now without equal in the market	++
Read-write head positioning technology for high capacity hard disc drives (HDD)	Project progressing well; excellent growth prospects	+++
Full recovery of IGT and medical markets	Remained slow in 2010 but signs of improvement for 2011	++
Divisional integration benefits and operational improvements	Integration proceeding to plan – “best of both” approach	++

# Agenda

- Overview of Morgan Ceramics
- 2010 results
- Project Concord – Mark Moore
- Superwool Strategy – Mark Moore
- Growth plans – Jim McRickard & Ian Robb
- Summary & closing remarks

# Morgan Ceramics

## Project Concord

Mark Moore

Director of Strategy Implementation

# Integration of the Technical and Thermal businesses is delivering real benefits

## Overhead reduction

A programme of work is underway to rationalise and simplify the organisation

## MTC Growth

Opportunities for Technical products in Asia and Latin America are benefitting from the resources of the combined division

## Benefits

On track to deliver £5m of cost benefits in 2011 with further upside to come

## Margins

The re-focused Operational Excellence programme will enhance gross margins and efficiency, particularly in Europe

## Product Strategy

A full review of fibre strategy has increased our focus on differentiation and on leading the market towards new formulations

# Concord structure is based on best-practice model

The Carpenter acquisition gave us a good model and toolset

Regular disciplines drive progress:

- Steering Group reviews
- Workstream reviews
- Tracking process
- Specific planning events
  - Edinburgh
  - Augusta
- Benefit quantification

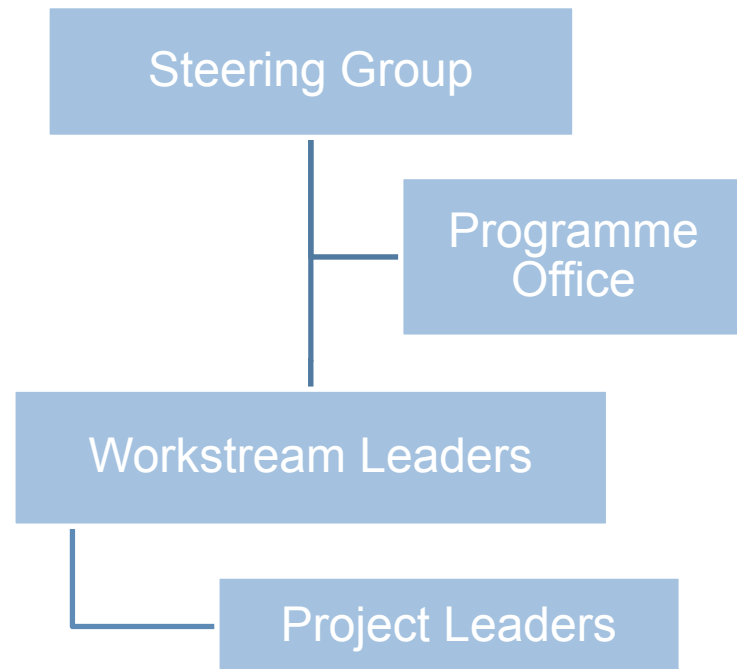

# 17 workstreams and 72 projects

Workstream	Projects									
Marketing	MKT1	MKT2	MKT3	MKT4						
Thermal Product Strategy	TPS1a	TPS1b	TPS1e	TPS2	TPS3	TPS4				
Thermal Product Strategy Asia	TPS1c	TPS1c_i	TPS1c_ii	TPS1c_iii	TPS1c_iv	TPS1c_v	TPS1c_vi	TPS1c_vii		
Thermal Product Strategy S America	TPS1d_i	TPS1d_ii	TPS1d_iii							
Regional Sales Growth	RSG1	RSG2	RSG3	RSG4	RSG5	RSG6	RSG7	RSG8		
M&A	AND1	AND2								
Continuity	CON1	CON2	CON3	CON4	CON5	CON6	CON7	CON8	CON10	
Operational Excellence	OXE1	OXE2	OXE3	OXE4	OXE5					
Overhead	OVH1	OVH2	OVH3	OVH6						
Working Capital	WCP1									
Procurement	PRO1									
Organisational Development	ORG1	ORG2	ORG3	ORG4	ORG5	ORG6				
Business & Reporting Structure	BRS1									
Distinctive Competencies	DCO1									
Operational EHS	EHS1	EHS2	EHS3	EHS4	EHS5	EHS6	EHS7	EHS8	EHS9	
Communications	COM1									
Controls	CTR1	CTR2								

# This workstream approach is delivering results

Concord achieves two principal outcomes:

- Better results and clearer divisional strategy
- Key workstream topics include:
  - Organisational design - Structure, people, values
  - Growth – use of best practice business development tools
  - Strategy development - Superwool, IFB, MTC growth in Asia
  - Operational excellence – Process benchmarking & Max Matrix
  - Overhead reduction
  - Marketing & communications
- Delivering £5m of cost benefits in 2011, rising to between £6m & £8m in 2012

# Morgan Ceramics

## Superwool Strategy



# Using material science to develop Superwool<sup>®</sup> fibre and satisfy demanding market requirements

Our latest generation of fibre products meet both performance and environmental requirements

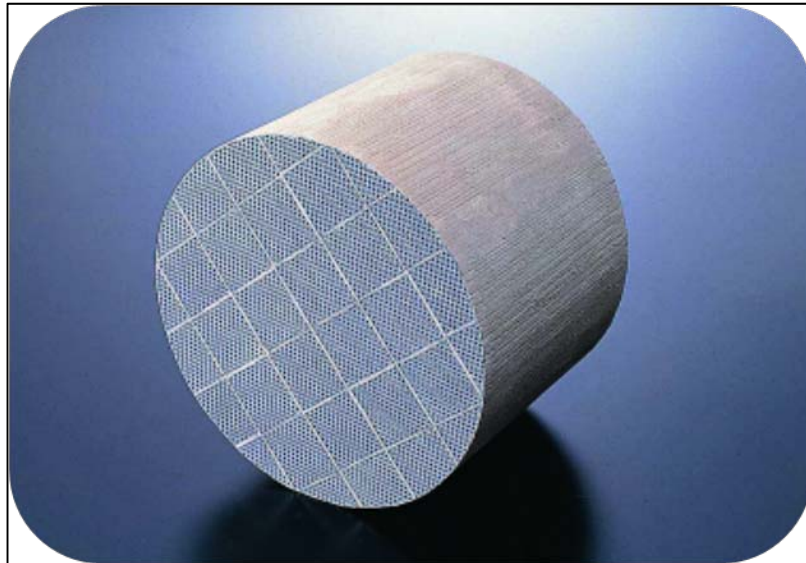

Function: Diesel particulate filter cleaning exhaust gases at high temperatures

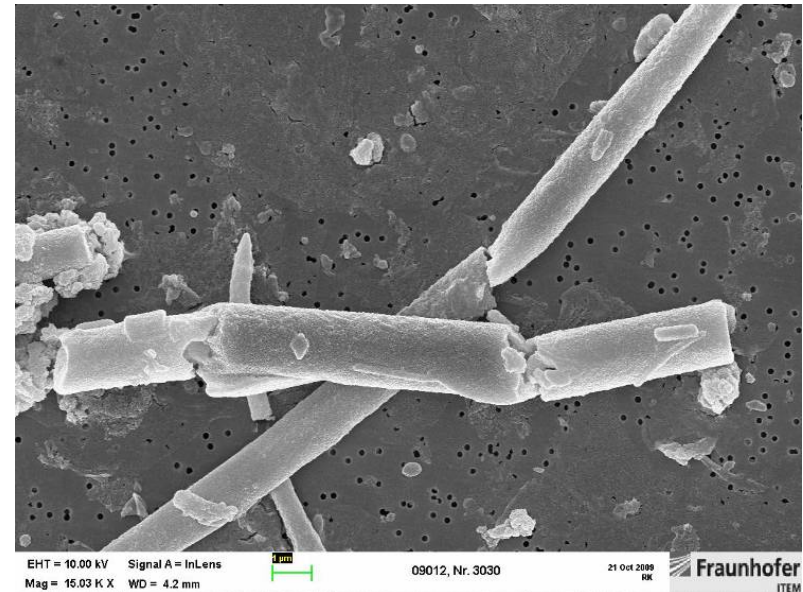

Environment: Our bio-soluble fibres lead the market in environmental performance

# Using the Superwool<sup>®</sup> strategy to drive value

- Completing the range of Superwool<sup>®</sup> fibre products will enable Morgan Ceramics to convert Refractory Ceramic Fibre (RCF) products into a higher margin business
- Third party fibre product sales in 2010 were circa £200m with one third from Superwool<sup>®</sup> fibre products
- Forecast growth is strong, with applications driven by megatrends
- Superwool<sup>®</sup> fibre products have protected IP

# Cable tray fire protection



**Firemaster:**

Encapsulated Superwool blanket

A growing market: maintain control in the event of a fire

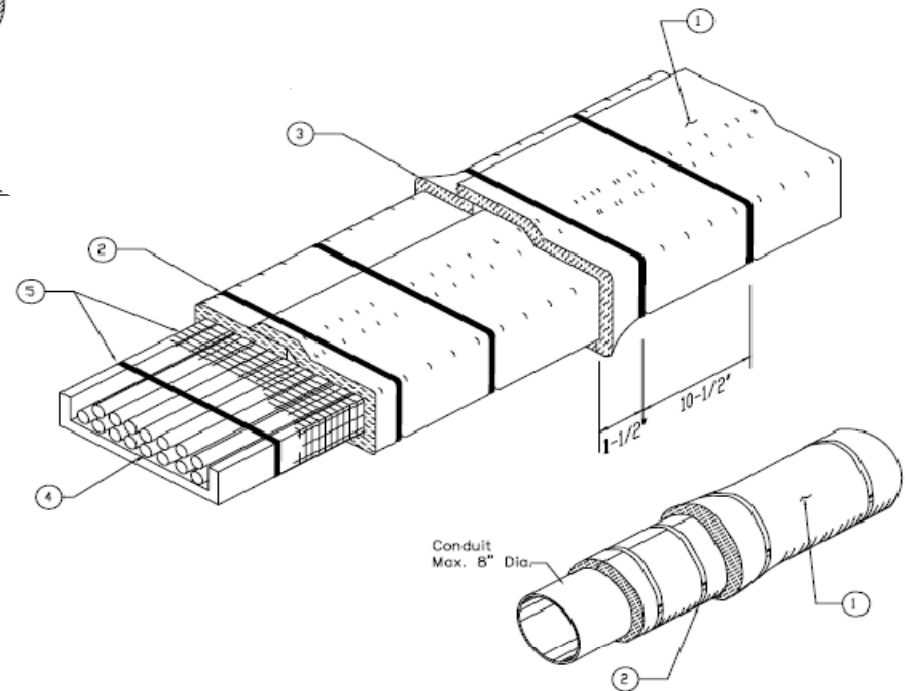

# Agenda

- Overview of Morgan Ceramics
- 2010 results
- Project Concord – Mark Moore
- Superwool Strategy – Mark Moore
- Growth plans – Jim McRickard & Ian Robb
- Summary & closing remarks

# Morgan Ceramics

Growth plans

Jim McRickard

President – North America

# Projecting significant growth from Aerospace

- ~ 26,000 new aircraft will be needed globally between 2011 and 2029
- Our products are used in instrumentation, control systems, engine monitoring, guidance systems and satellite positioning
- Significant growth forecast from a range of products, including:
  - Investment casting cores, Braze Alloy Products & Thermal management and fire protection

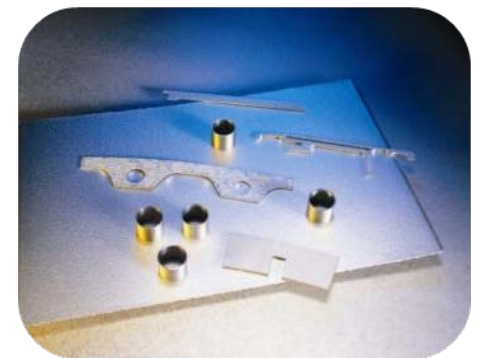

# Projecting significant growth from Medical

- Healthy pipeline of new products into Western markets
- World leader in the design and manufacture of ceramic implants and assemblies
- Significant growth forecast driven by:
  - \$30bn global market for cardiovascular, neuromodulation & surgical devices
  - Innovation in the development and advocacy of less invasive devices

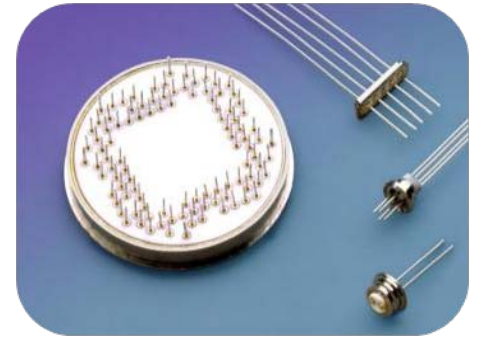

# Collaboration with MIT and BMES

## High density feedthroughs for Ocular implants

- Next generation device
- Improved telemetry coils and hermetic casing
- BMES Development
  - Argus I - 16 electrodes in 25mm took 15 years
  - Argus II 60 electrodes in 5mm took 5 years

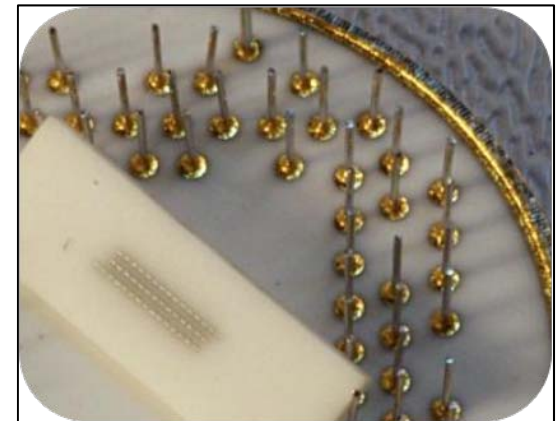
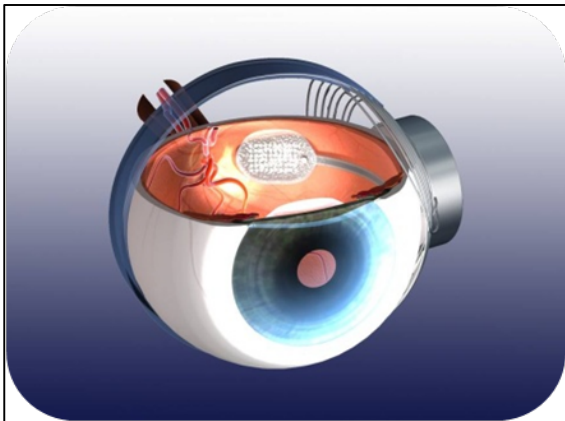
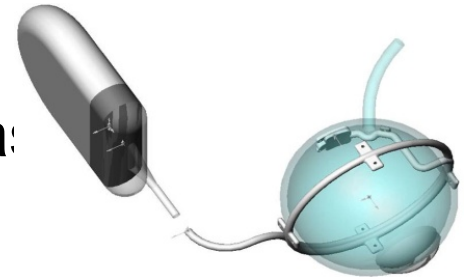



# Projecting significant growth from Semiconductor Processing & Electronic Data Processing

- Creativity in the application of technologies will drive growth by improving efficiency and reducing the cost of information
- Significant growth forecast supported by:
  - Strong new product offerings – CMP Phoenix<sup>®</sup> Edge and Sharkskin<sup>™</sup>
  - Major growth program for HDD application utilising manufacturing in Malaysia

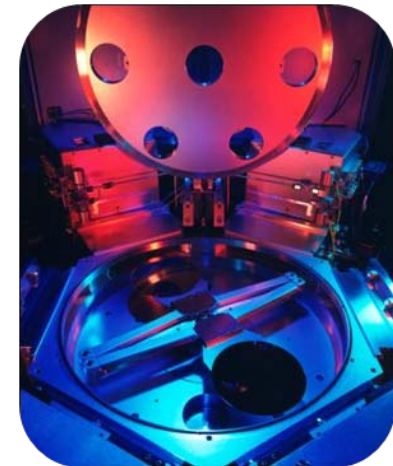

# Patented CMP Pad Conditioner – Phoenix<sup>®</sup> Edge next generation conditioner

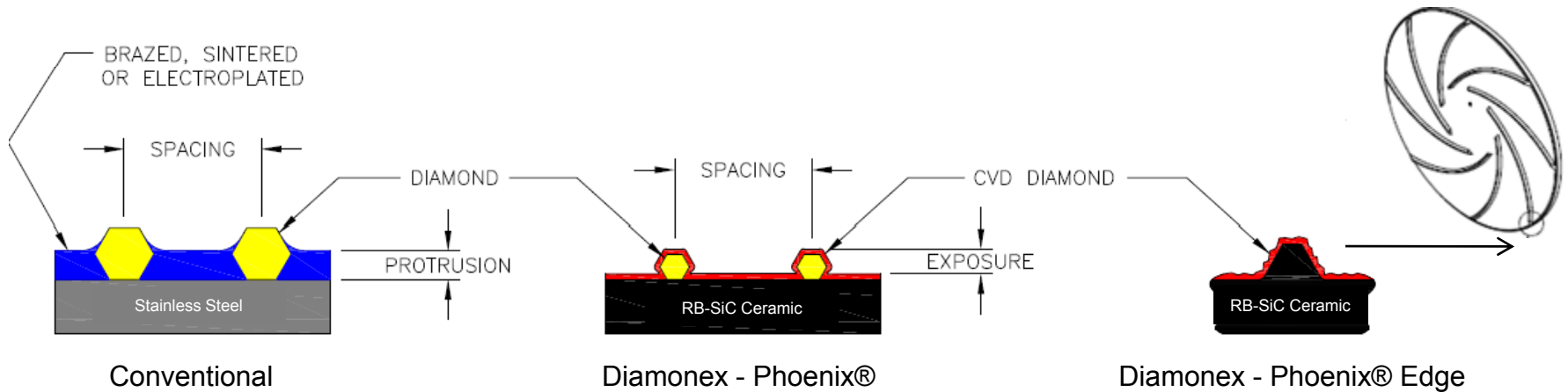

- Reaction Bonded Silicon Carbide (RB-SiC) disc produced by Morgan AM&T
- Chemical Vapour Deposition (CVD) Diamond coated for high performance
- Significantly outperforms conventional conditioners in demanding CMP applications



# Patented Sharkskin™ Surface Texturing for semiconductor PVD & CVD processes

- A well-controlled, high-roughness surface texturing integral to the alumina base material
- Improves process residue adhesion and reduces overall particulate defects
- Greater holding power to residue build-up, extends time between PM cycles
- Enhances or replaces aluminum twin-arc spraying (TWAS)
- Replaces damaging bead blasting process
- Texture identical composition to substrate
- High roughness without sub-surface damage
- Acid and plasma resistant 99.8% alumina

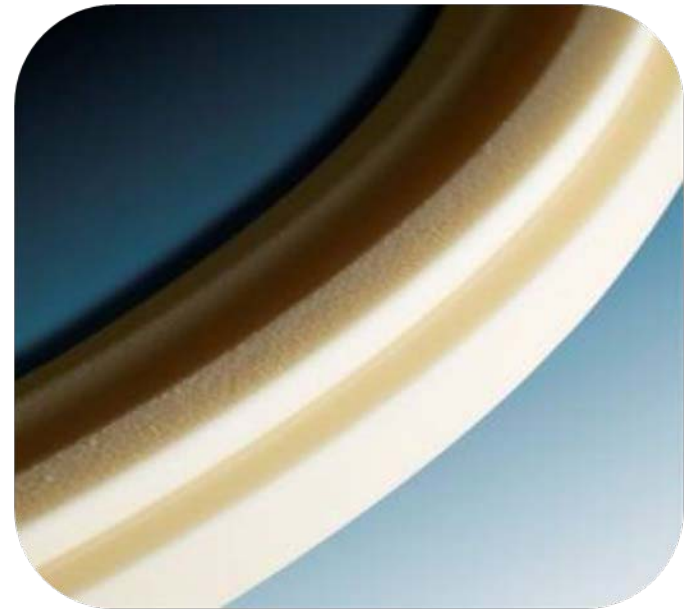

# Positioned for a huge market opportunity with tiny piezoelectric ceramic components in data storage

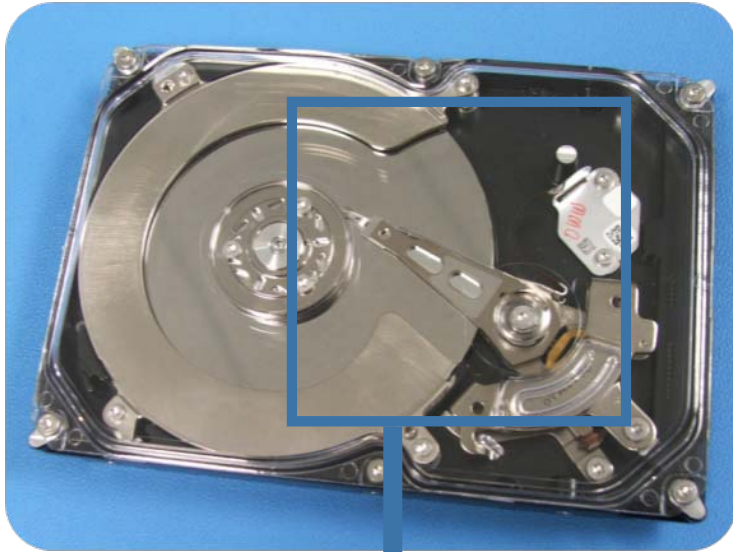

Ceramics is working with computer disk drive manufacturers to incorporate piezoelectric components on the next generation of drives

These components allow for improved control of the read-write head, which enables data density to increase allowing more data per disc and drive to increase total storage

We are partnered with the market leader

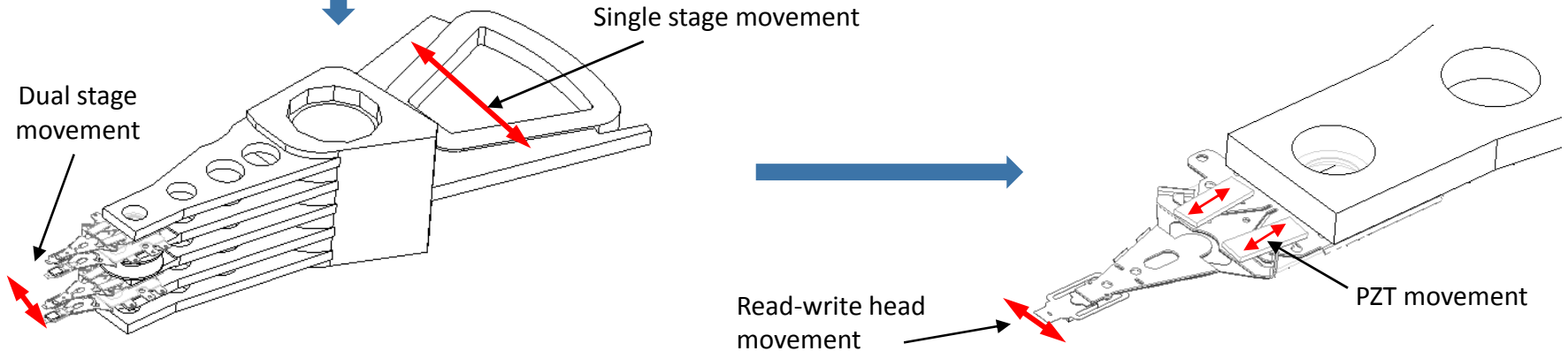

# Morgan Ceramics

Growth Plans

Ian W Robb  
President Asia

# Strategic intent: To capitalize on positive market dynamics

- Main investments in China, India & Middle East
- Focus on selected markets with megatrend drivers
- Drive operational excellence for cost efficiency and quality
- Localise manufacturing content in Asia
- Drive Superwool® Fibre strategy for Asia
- Increase Technical Ceramics sales
- Continually drive EHS and business controls standards
- Further strengthen regional team by end 2011, to lead rapid growth of our business

# We are well placed with sales in rapidly growing and demanding applications

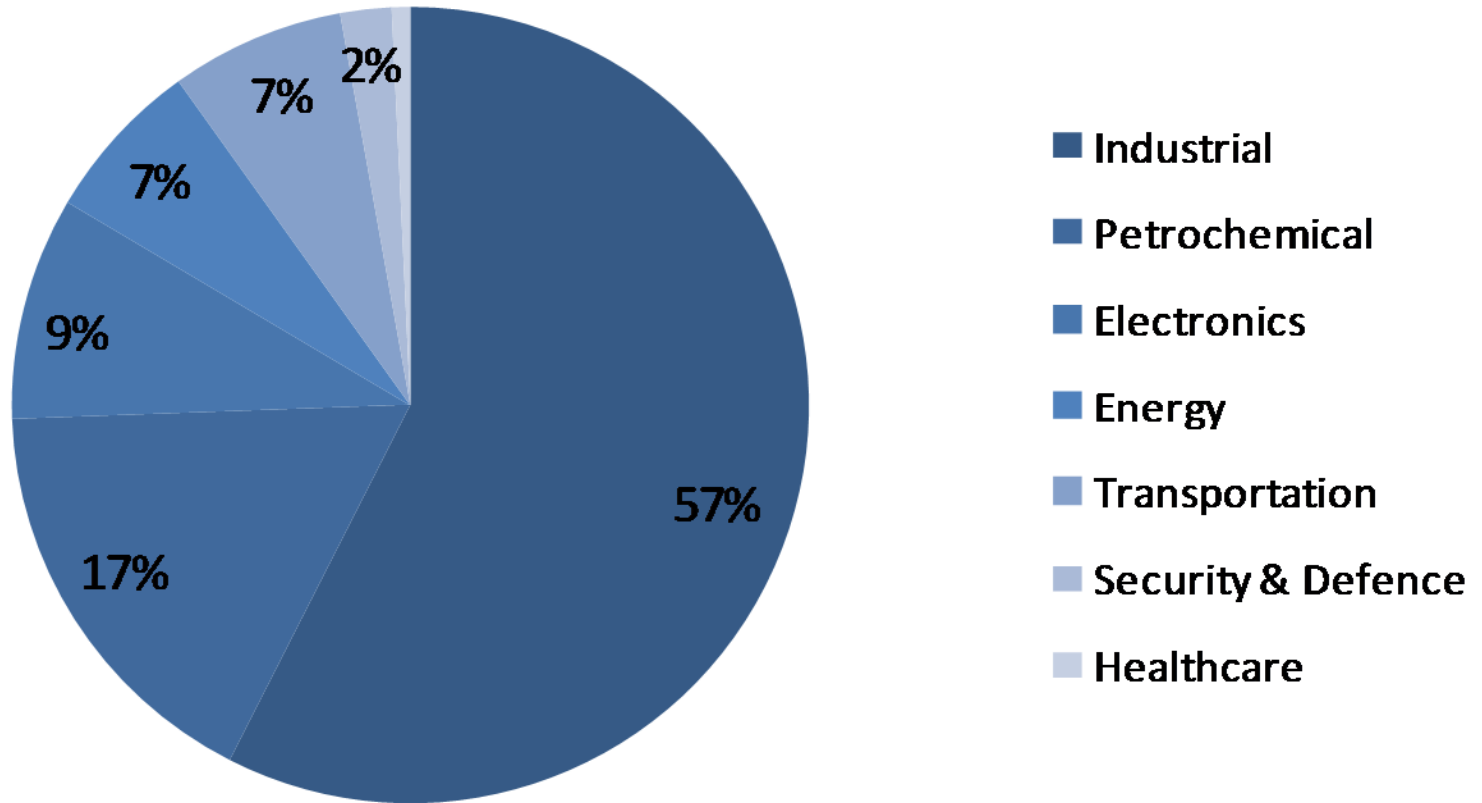

Morgan Ceramics sales by market into Asia region 2010

# Asian market dynamics and megatrend drivers create differentiated product opportunities

- Asia has >60% of world population (6.9bn est. 2010)  
China and India together hold 40%
- People need power, fertilizers (chemicals), infrastructure (steel, glass, aluminium, ceramics) and general manufacturing equipment
- Growing affluence (middle class) in India and China and ageing populations of Japan and Korea
- Growing alignment and opportunities with medical, water purification and EHS
- Firmly focusing on the technologies with the greatest commercial opportunity given these dynamics



# China energy demand to increase by 75% over 25 years

- China overtook America to become the world's largest energy user
- Global demand for energy will increase by 36% to 2035
- Emerging economies will account for 93% increase
- Fossil fuels remains the dominant source of energy in 2035
- Renewable energy sources rise
- Demand for coal and oil in OECD countries will fall 44% to 33%

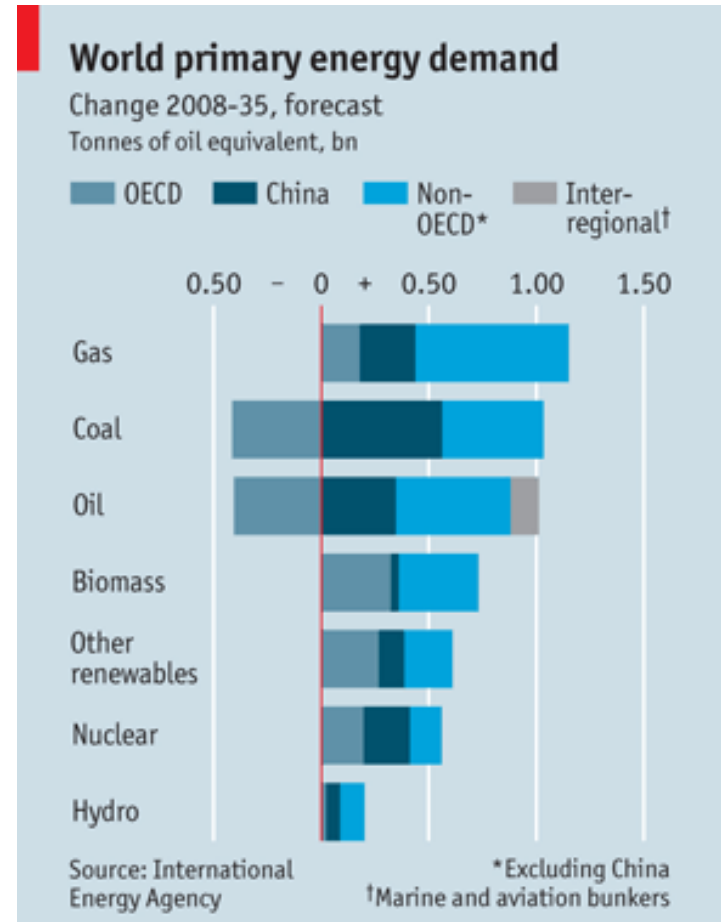

Source: The Economist 13<sup>th</sup> November 2010

# Asia leads global steel production and demand

- World steel production 1,414 million metric tons (mmt)
- Asia's Annual production share 63.5%
- China 44.3% of world production
- India's potential for steel is huge; their per capita steel consumption is only 35 kg compared to 150 kg in the world and 250 kg in China
- Estimated that by 2015-16, India would become the second largest steel producer

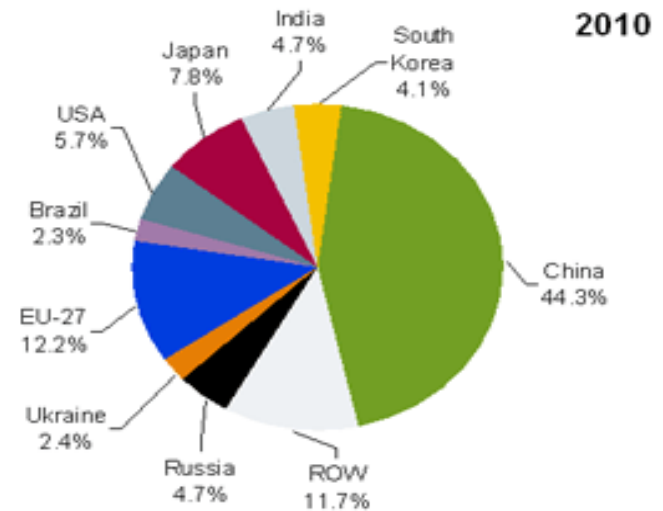
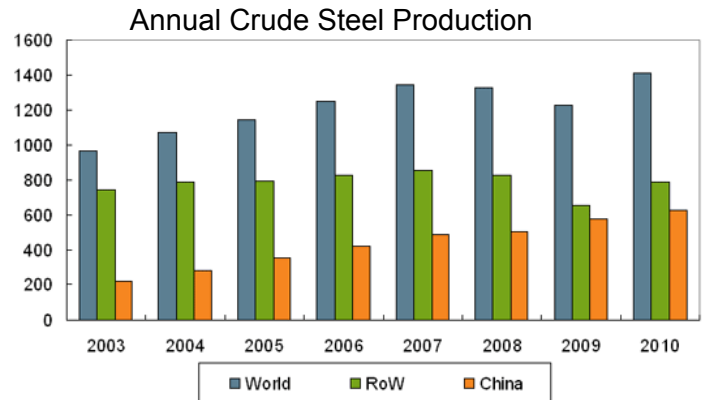

Share of world crude steel production 2010

Source: [www.worldsteel.org](http://www.worldsteel.org)

# India, China and SE Asia showing robust growth and attracting strong investment in petrochemicals

- Asia's petrochemical opportunity estimated to be 50% of the global chemical volume growth
- Ethylene growth led by China the world's biggest producer (25%) and consumer (30%)
- China's Sinopec expanding from 9.5m tonnes per annum (tpa) to 13.5mn tpa by 2015
- In India 43m tpa additional refining capacity next 5-6 years
- Singapore is positioning to become an advanced oil, chemicals and lubricants hub

FDI Net (USD Bn) in India

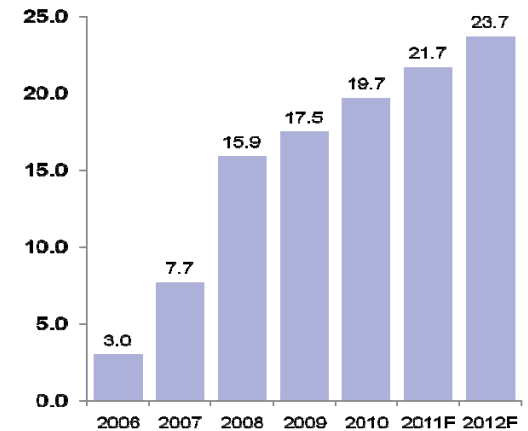

Ethylene capacity versus consumption

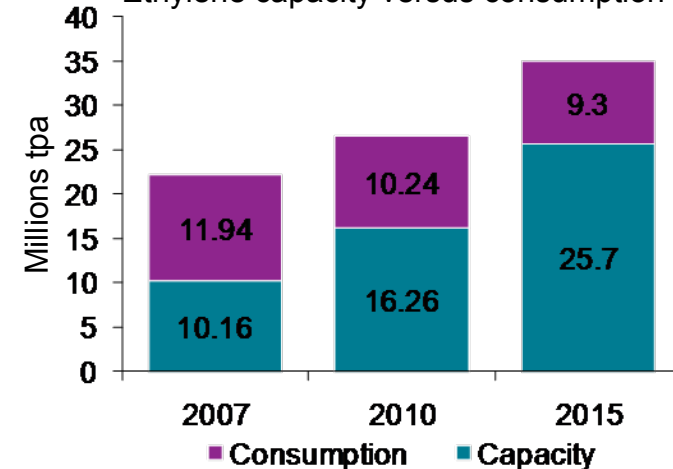

Source: KPMG Report

Source: BMI China Petrochemicals Report Q1 2011

# Bringing proven technology and processes to the growing Aerospace industry in Asia

- Singapore developing major engineering and repair facility
- Completed by 2018, creating 10,000 jobs, doubling sector output from S\$6.3bn
- Key players include Rolls-Royce and Eurocopter SEA
- By 2015 Chinese and Indian markets high growth
  - India: CAGR 13.1% with investment of \$36.2bn
  - China: CAGR 15.6 % with investment of \$185.7bn
- 500m air passengers in China
- Commercial aircraft growth from 2600 to 4500
- Helicopter purchases in China will reach 3300
- China aircraft production increases dramatically



Annual passengers in China

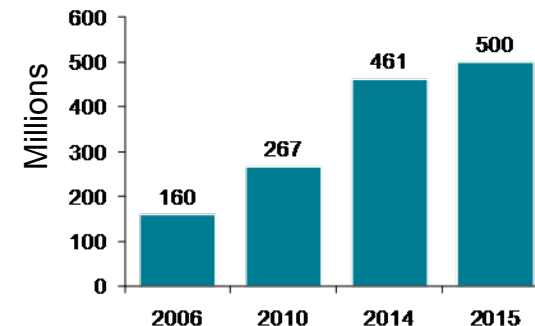

Source: KPMG Report

# Population growth and increased life expectancy creating exciting new opportunities in medical

- Life expectancy increasing through medical advancement and public health measures
- China's five year plan stimulates foreign investment in the medical device sector
- Medical Implant assemblies, Hermetic Seals in X-Ray market segments
- China production **versus** importing; significant tax advantages and government funding
- Healthcare and medical devices planned expenditure CNY850bn 2009 -11 plus
- Medical Equipment CNY1.7bn in rural China
- China Improves re-imburement schemes
- Singapore Government. invests S\$3.7bn in Biomedical research through 2015

Change in Aging Rate in Asia

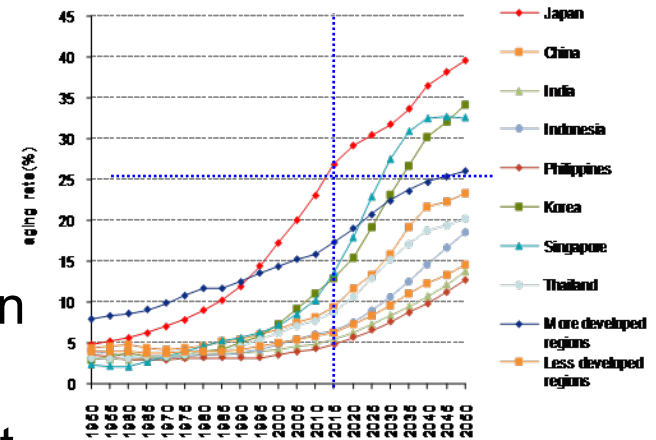

Source: KPMG Report

# In this exciting, diverse market we are experiencing real megatrend growth

- Optimise our Superwool® Fibre growth plan and increasing output of converted products are driving our margins higher, by adding valued solutions
- Technically differentiated engineering solutions, driving opportunities in Asia for both Technical and Thermal solutions
- Western based customers of aerospace, medical and high tech components are re-locating or investing in Asia
- Specific opportunities already identified for growth from domestic manufacturing in Asia
- Strengthening alliances with existing partners in India and China to utilise our international expertise with their local competences



OEM Water Boiler using Superwool® PLUS™ Fibre

# Agenda

- Overview of Morgan Ceramics
- 2010 results
- Project Concord – Mark Moore
- Superwool Strategy – Mark Moore
- Growth plans – Jim McRickard & Ian Robb
- Summary & closing remarks

# Morgan Ceramics

Summary & closing remarks

Andrew Hosty  
CEO



# The Division's plans fully support Morgan's aim of doubling PBT

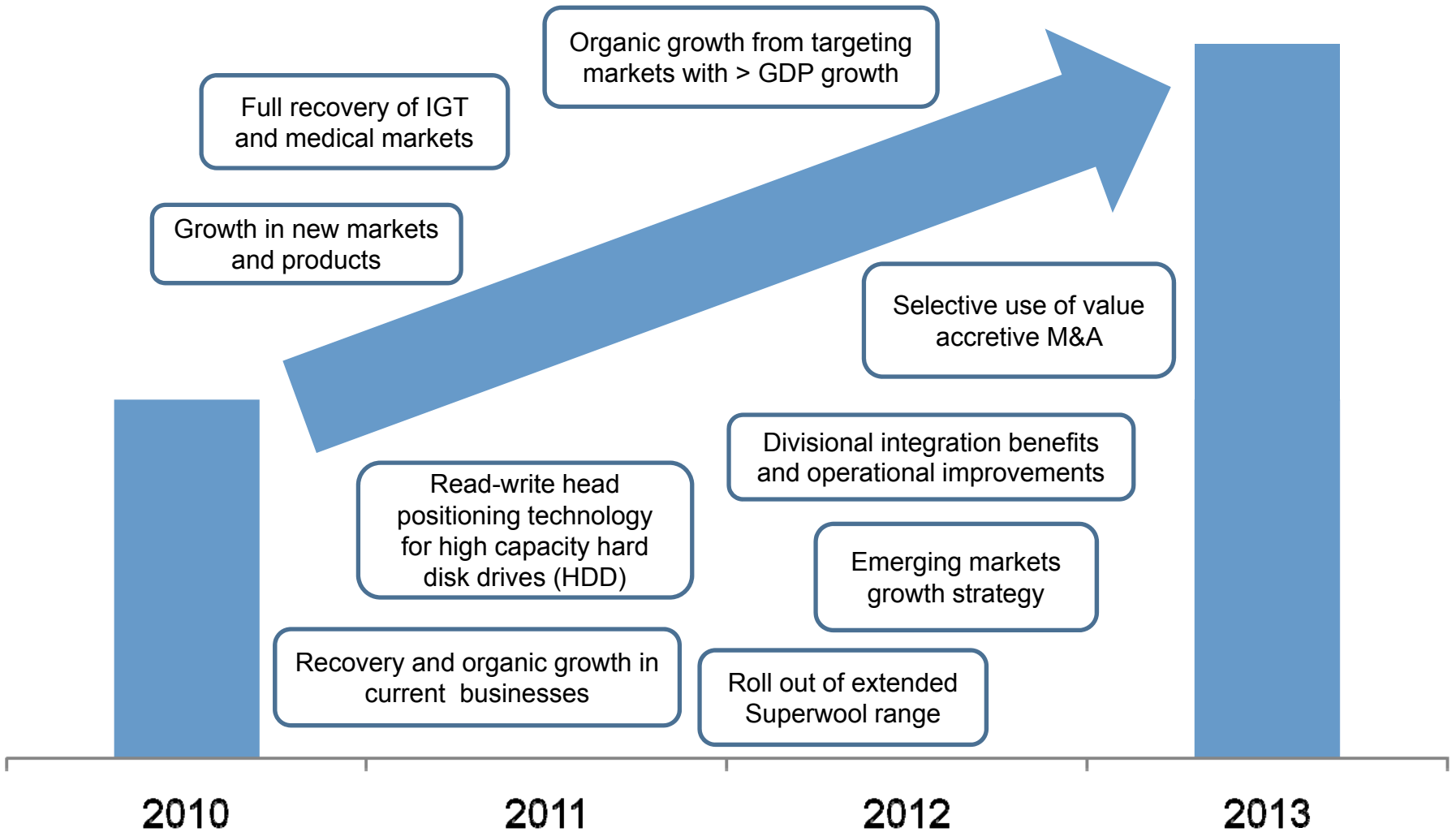

Any questions?

# CAPITAL MARKETS PRESENTATION 31 MARCH 2011, LONDON

*Engineered Materials Division*

Don Klas

# Agenda

- Reflect on our journey
- 2010 review
- Overview of our businesses
- 2011 and beyond

# Looking back

- Success in US ceramic body armour led to our acquisition of NP Aerospace
- We demonstrated resilience through the worst economic downturn of our lifetime
- Established globally aligned teams that leverage our global reach

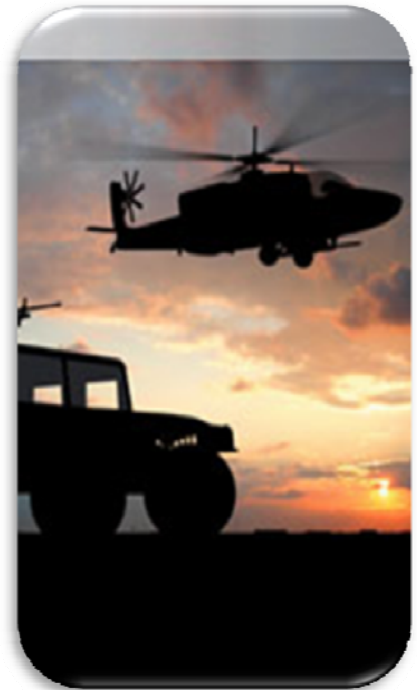

# Our commitment to investing in technology

... is yielding breakout technically differentiated solutions for solar and LED

...has led to our entry into the lithium ion space

...and to a burgeoning pipeline of new materials technologies and engineered solutions



Today we have 3 strong brands serving our markets

## Engineered Materials Division



# ...delivered through locations in 25 countries providing global scale and reach

c.4,000 employees    35% in low cost countries

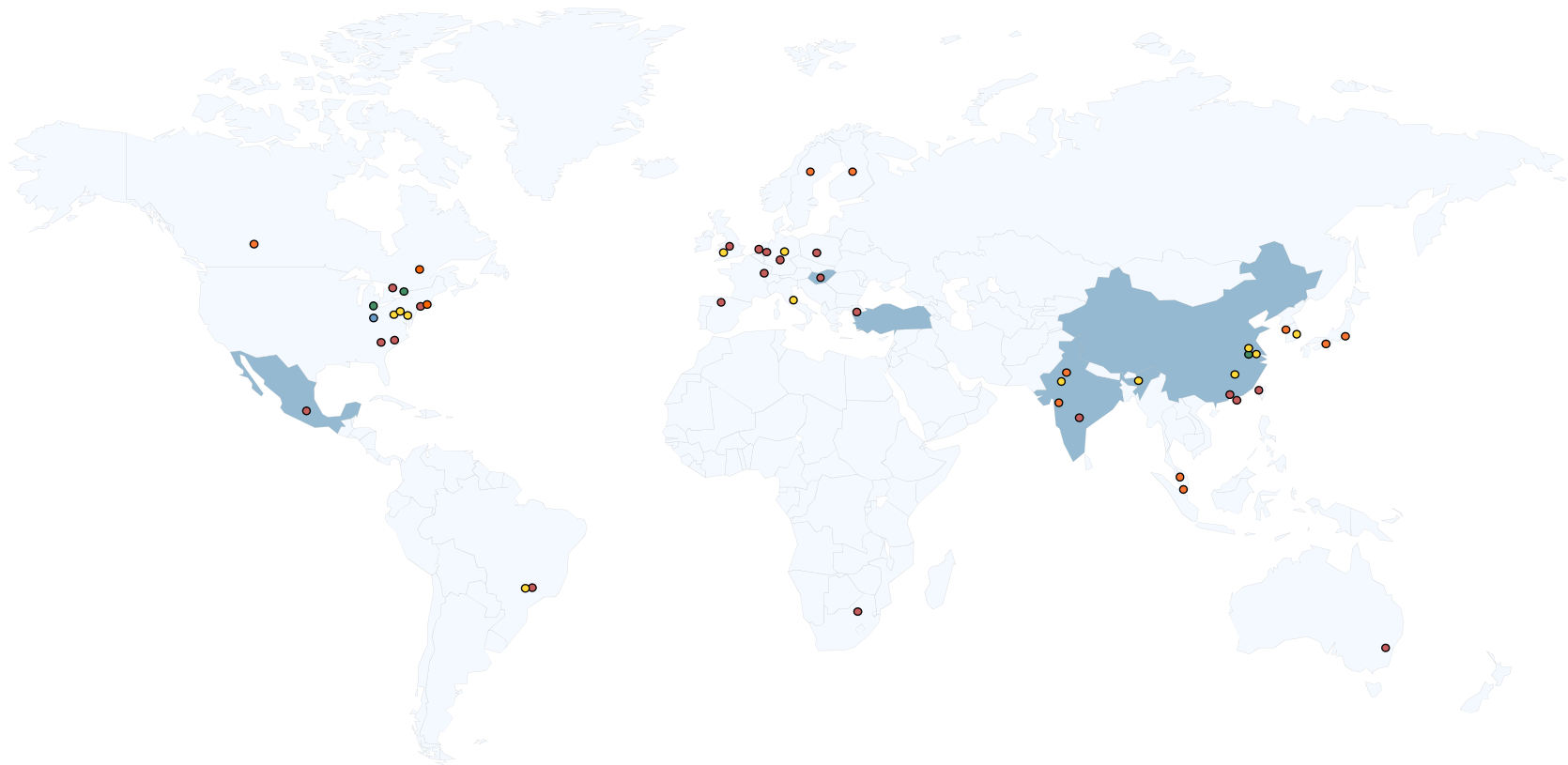

● Materials    ● Materials and Finishing    ● Finishing    ● R&D    ● Distribution



## ...and through the economic crisis we have reshaped our cost base

- Significantly trimmed AM&T overheads in the West with more opportunities looking forward
- Moved direct labour to low cost countries while building capability and scope to continue
- More than doubled our resources in China and we are continuing to add talent and bandwidth
- Increased our investment and capability in technology development with intentions to continue

# Engineered Materials: profits up year-on-year with non-NP Aerospace revenue increasing c.22%

£m	Revenue		EBITA pre-restructuring and one-off items		Profit Margins %	
	<u>FY10</u>	<u>FY09</u>	<u>FY10</u>	<u>FY09</u>	<u>FY10</u>	<u>FY09</u>
AM&T (formerly Carbon)	246.8	205.2	22.1	11.6	8.9%	5.7%
NP Aerospace	120.9	186.2	17.1	28.9	14.2%	15.5%
Molten Metal Systems	40.3	30.1	6.3	0.9	15.6%	3.0%
<b>Engineered Materials</b>	<b>408.0</b>	<b>421.5</b>	<b>45.5</b>	<b>41.4</b>	<b>11.2%</b>	<b>9.8%</b>

- Profits up £4.1 million on lower revenue following the exceptional level of sales by NP Aerospace in 2009
- 22% increase in non-NP Aerospace revenue driving significant improvement in AM&T and MMS margins

# Engineered Materials – revenue sources

- 80% of the Division's turnover is in Europe and America, however, China grew more than 40% in 2010 with prospects for continued strong growth in 2011
- 60% of turnover is in our traditional businesses where aggressive growth strategies are targeting GDP growth or better over the next few years
- The remaining 40% of turnover provides significant scope for growth

## 2010 Revenue by Region

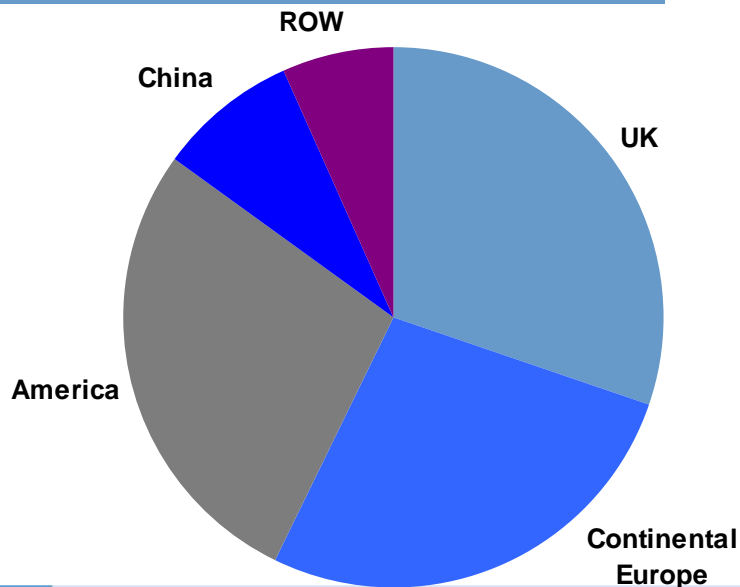

## 2010 Revenue by Business

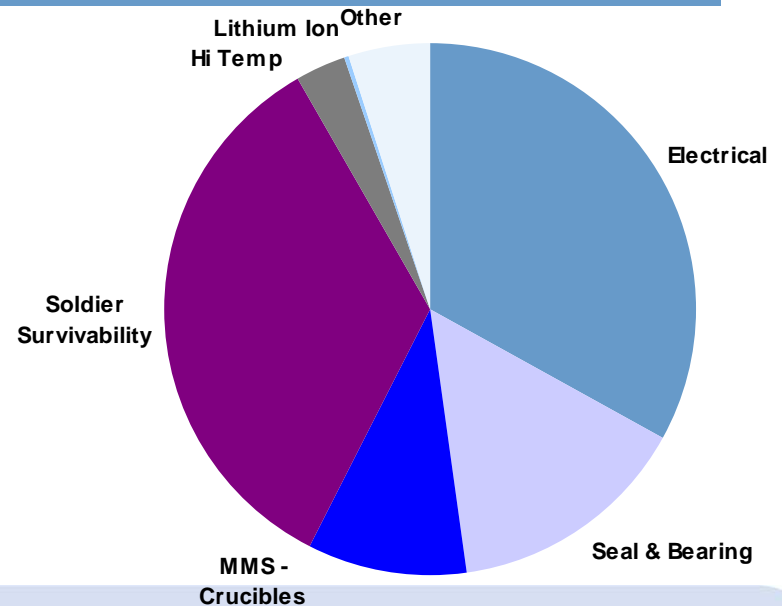

# Key value drivers for 2011 and beyond

	2010 Position	Future Prospects
Extracting GDP or better growth from our base industrial businesses	Ongoing recovery from the 2009 downturn	++
Growth in the clean energy sector	Good progress made in Wind and Solar. Lithium Ion acquisition	+++
Capitalising on Chinese growth	>40% growth seen in 2010. Strong in-country presence	+++
Driving cost-efficiencies throughout the business	34% of divisional direct labour now in low-cost economies	+
Expanding our survivability business internationally	US NP Aerospace office established in Detroit	++
Developing tomorrow's technologies	R&D centres established around the world	++

# CAPITAL MARKETS PRESENTATION 31 MARCH 2011, LONDON

*Engineered Materials Division*

## Businesses Overview

# 6 Key Businesses

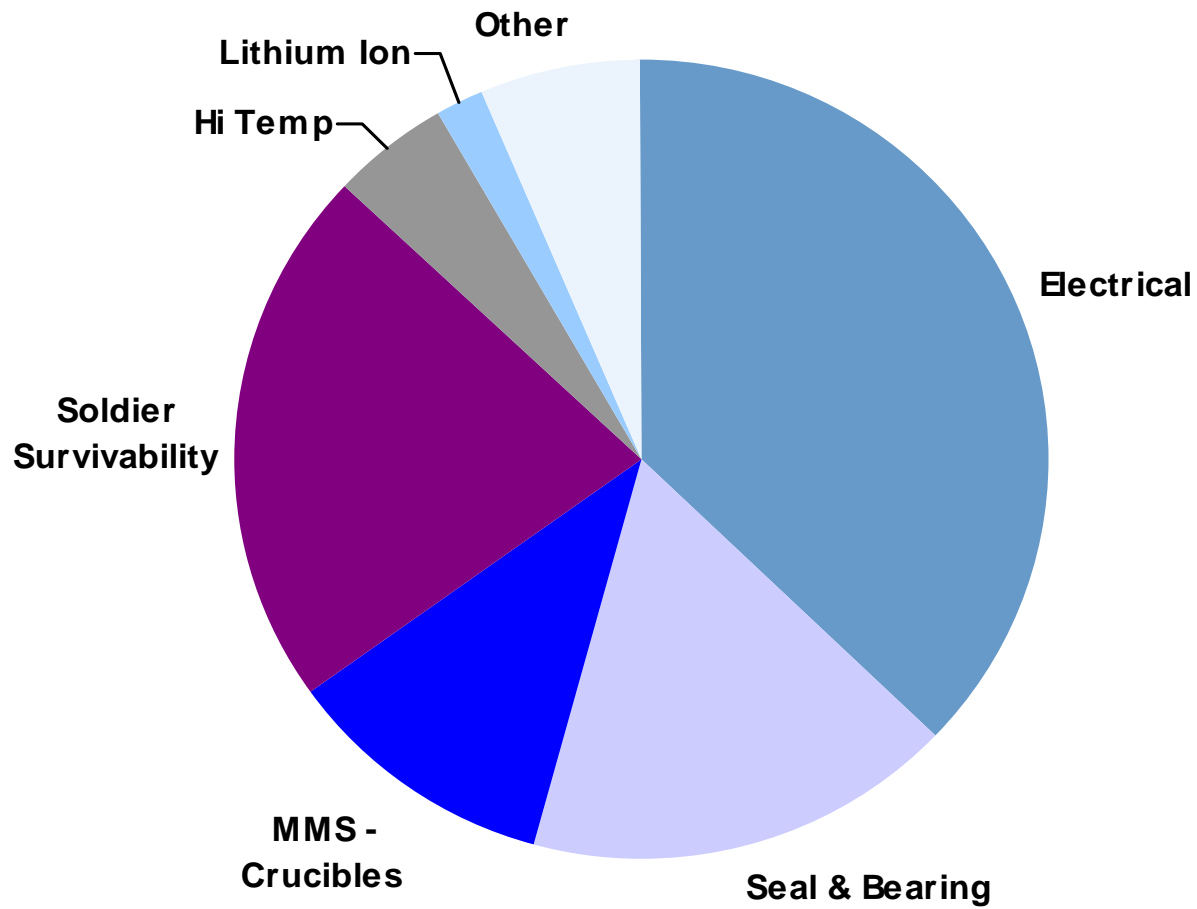

## Applications



## Products



- Built upon Morgan's long standing global industrial & traction carbon brush business
- Continues to deliver healthy gross margins
  - materials technology
  - application engineering
  - service
- Together with our Seal & Bearing business delivers the global platform that provides us the reach and scale to penetrate new markets



## Industry Drivers

Operating efficiency and uptime for critical applications in industry, mining, power gen, and rail transport

## Growth Trends

< GDP due to conversion to brushless offsetting growing demand from rail traction and wind

## Megatrends that impact

Rail transport growth in Emerging Markets. Wind energy growth in China and the US

## Target Market

£350m

## Current Market Position

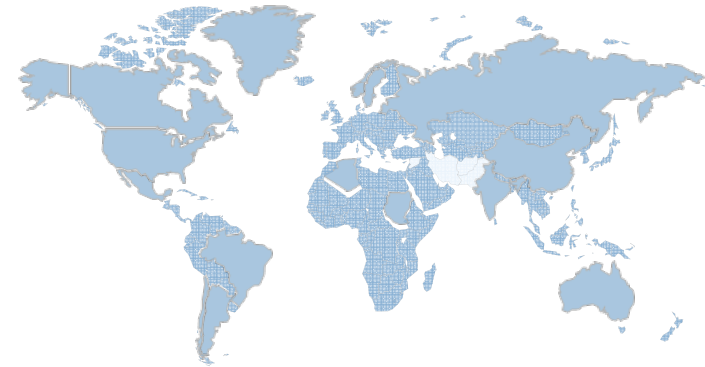
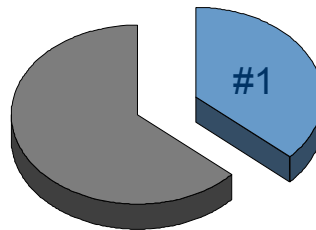

Consumable

## Strategic Focus:

Rail, wind, winning in Emerging Markets

0%

100%

## Applications



## Products



- Delivering solid and improving gross margins
  - highly engineered products
  - materials technology
  - global network of application engineers
- Positive growth prospects
- Recognized as the only true “Global Supplier”
- In early 2000’s the technologies and capabilities of this business; namely our expertise in sintered silicon carbide, spawned our successful entry into the US body armour market

# Seal & Bearing Business

## Industry Drivers

Operating efficiency, uptime and performance in critical applications for chemical processing, oil & gas, aerospace and water

## Growth Trends

GDP + with high growth in China and in oil & gas  
Increased investment when oil price is high

## Megatrends that impact

Industrialisation and urbanisation in Emerging Markets

## Target Market

£250m

## Current Market Position

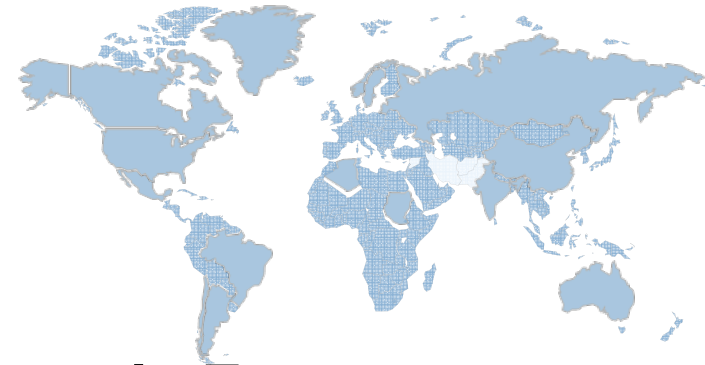
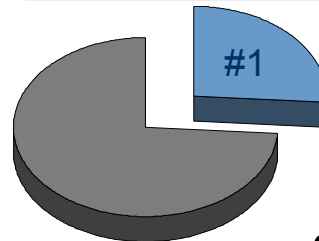

## Strategic Focus:

Grow market share with focus on China and Emerging Markets - capitalise on status of being only true global supplier

## Applications



## Products



- Morgan's original business - founded in 1856
- Continues to deliver healthy gross margins due to exceptional
  - materials technology
  - application engineering
  - extensive global distribution network
- 2010 first full year of operation for new India and China plants

## Industry Drivers

Demand for high quality metal castings used across a broad range of end user markets and increasing demands for higher purity metals

## Growth Trends

Growth at GDP+ in Emerging Markets

## Megatrends that impact

Rapid industrialisation and population growth drive usage

## Target Market

£100m

## Current Market Position

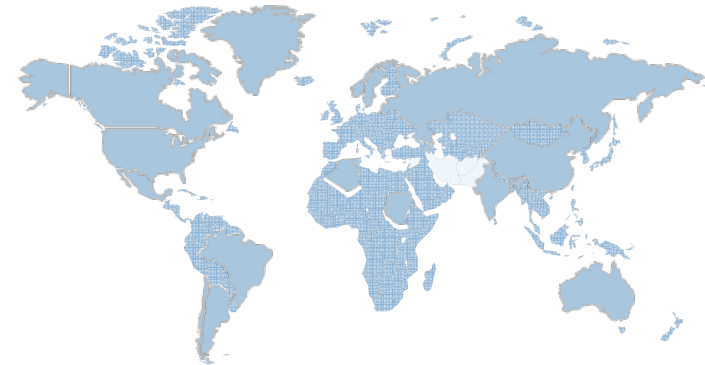
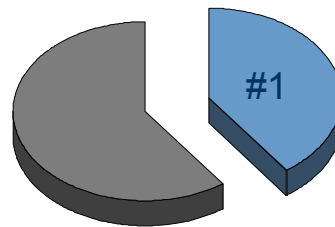

Consumable

## Strategic Focus:

Grow market share in Asia and other Emerging Markets

0%

100%

# Soldier Survivability Business



## Applications



## Products





# Weight has become the pervasive issue



**Military Vehicles** are significantly overweight. The tension between survivability and mobility is driving the need for new, advanced lightweight solutions.



**Soldiers** today are over burdened with armour, batteries, communications, etc. causing severe strain. Their current load is > 50 Kg – new lightweight solutions needed.

# So weight is the opportunity that our investment in technology targets

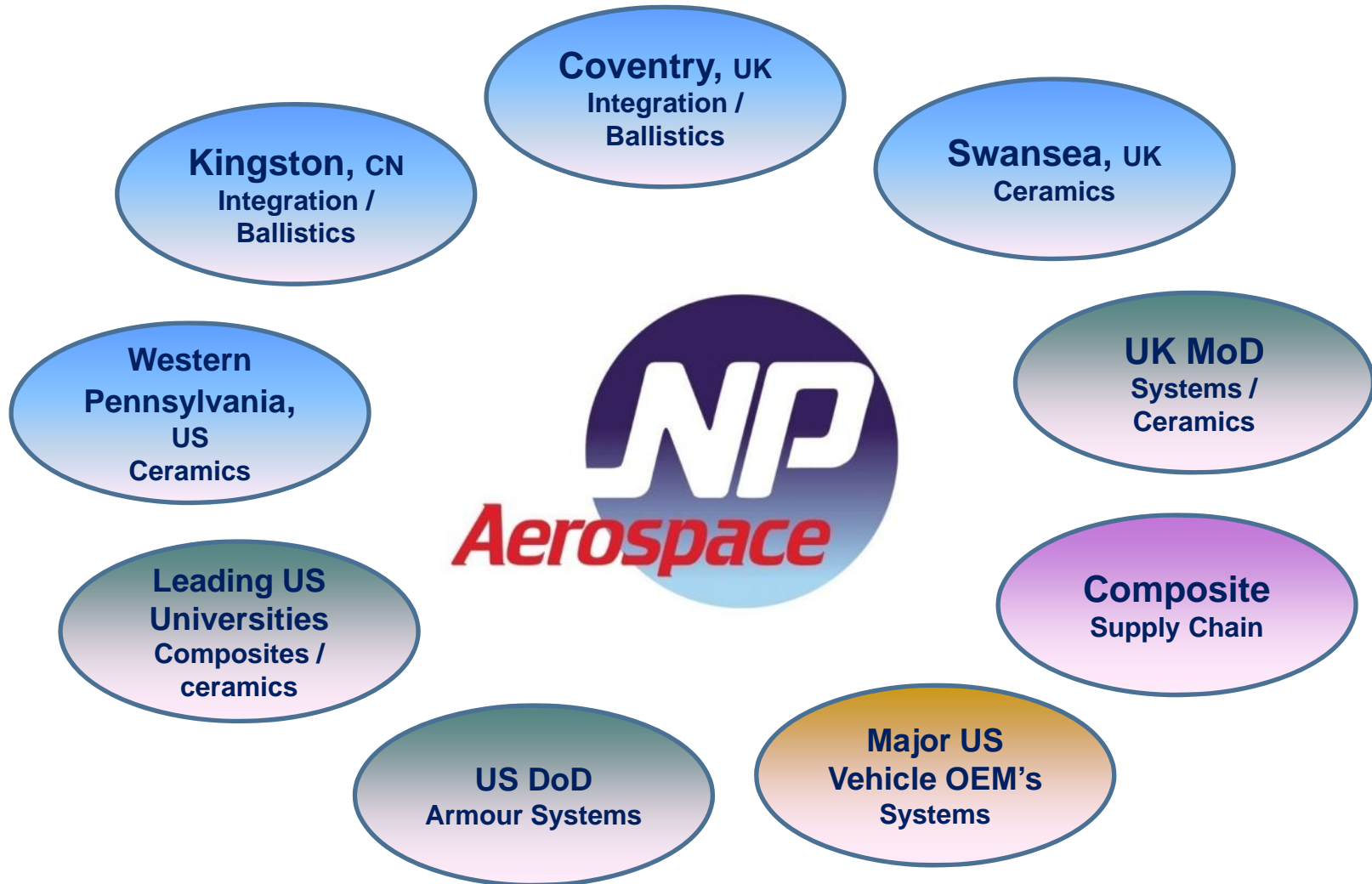

# Soldier Survivability Business



## Industry Drivers

Weight reduction & increased payload, escalating threats, increasing mobility requirements

## Growth Trends

Shrinking budgets but emphasis on soldier survivability and mobility increasing worldwide

## Megatrends that impact

Escalating global conflicts and tensions mean that countries are re-evaluating their survivability capabilities

## Target Market

£1,000m

## Current Market Position

OEM

0%

100%

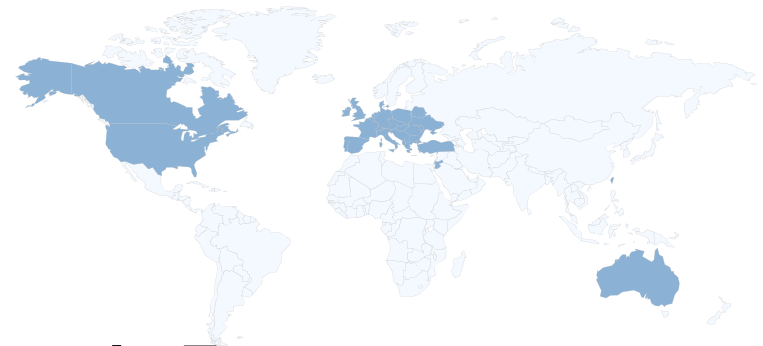
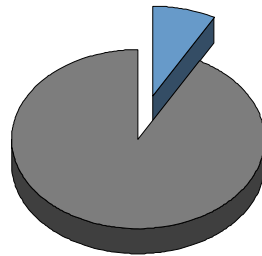

## Strategic Focus:

Leverage Division's global reach and NPA / AM&T technology portfolio to penetrate US and other major militaries – continue to invest in R&D

## Applications



## Products

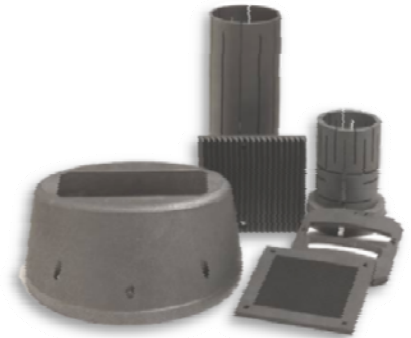

# The solar market's rapid growth is driving demand for high temperature insulation solutions

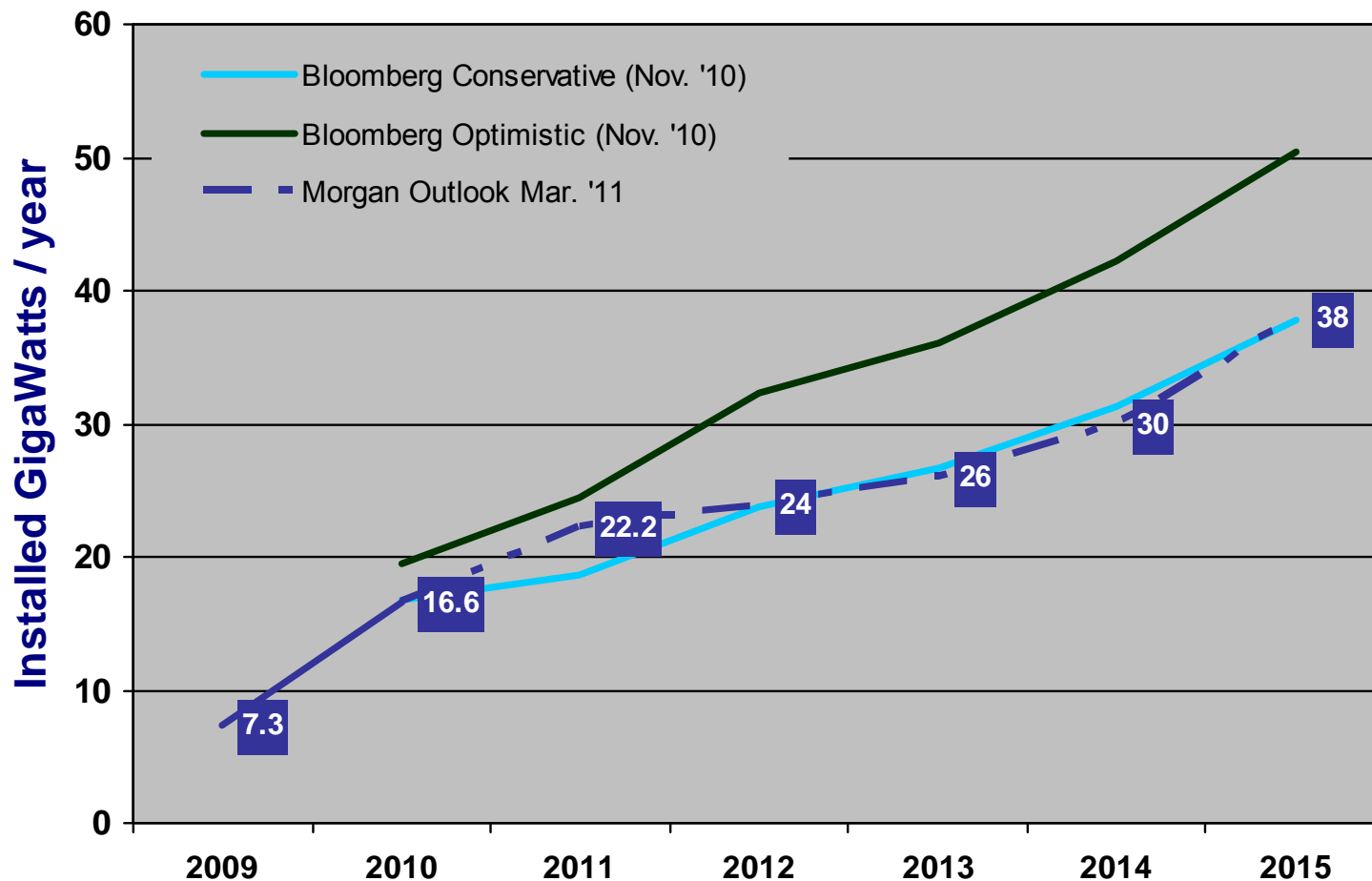

...yields, cell efficiency, energy consumption and life cycle cost are rising in importance for solar cell production

## Morgan's enabling technologies.....

### CZ Furnace Mono-crystalline Si

Soft felt  
wrap or  
rigidized  
cylinder

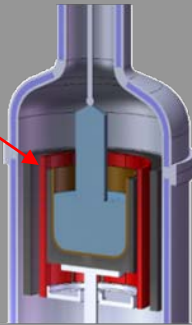

- up to 48% energy savings
- up to 15% higher yields
- up to 50% extended life
- Improved cycle times

### DSS Furnace Multi-crystalline Si

Rigid  
board or  
rigidized  
felt board

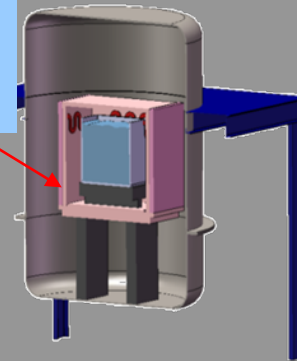

- 1-2% higher yields
- Improved cell efficiency
- 1% cell efficiency = \$100k
- now data sharing with high-end players

### Polysilicon Converter

Rigid  
board or  
rigidized  
felt  
cylinders  
& graphite

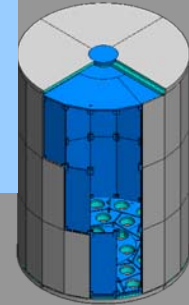

- 20% avg energy savings
- 2X demonstrated thru put
- Engaged with end-users and OEM's

Demand for sapphire based High Brightness LED's has grown exponentially / driving demand for Morgan's high quality felt

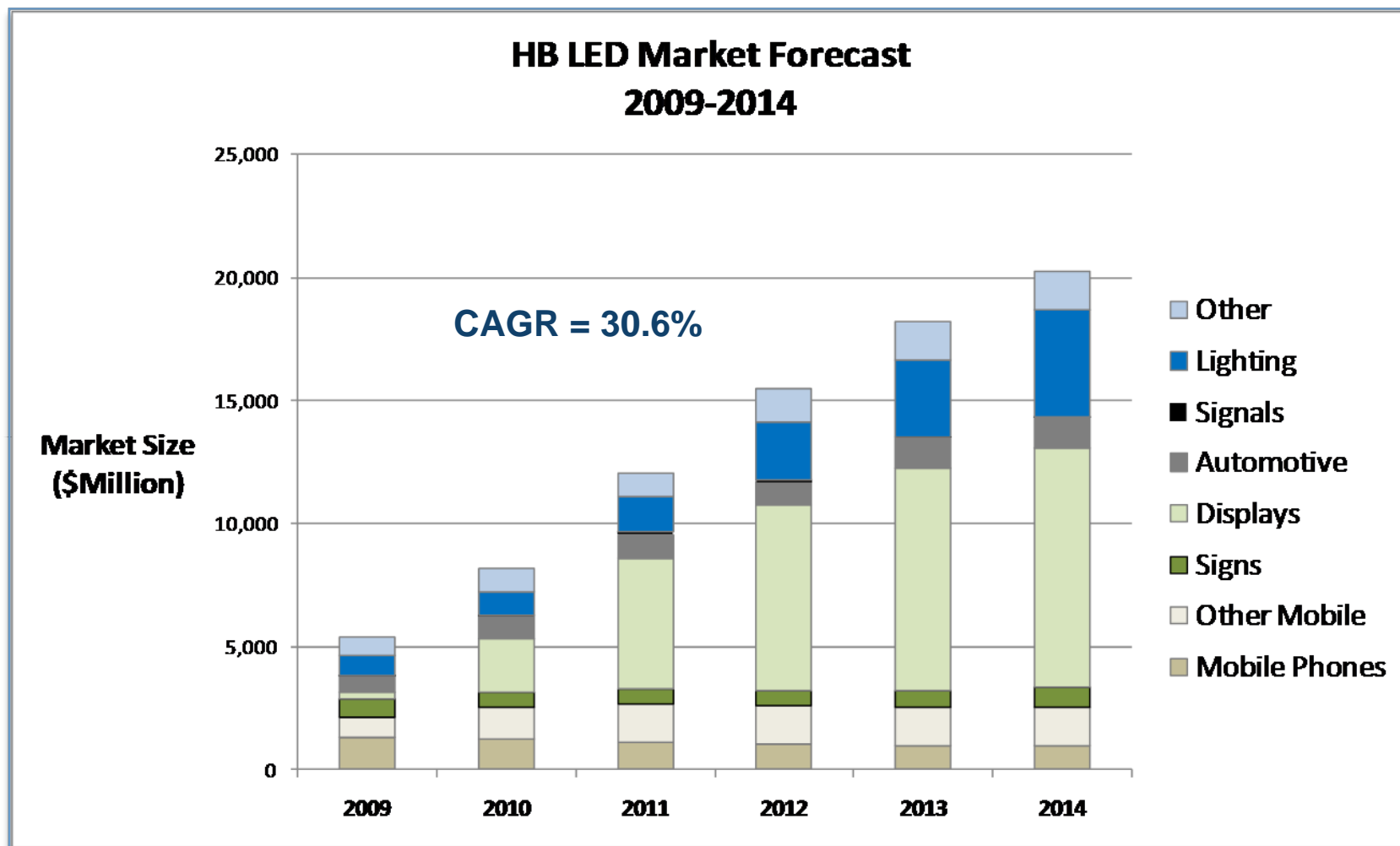

# Sapphire crystal production is in early stages, but investment is exploding



Soft felt wrap used in hot zone

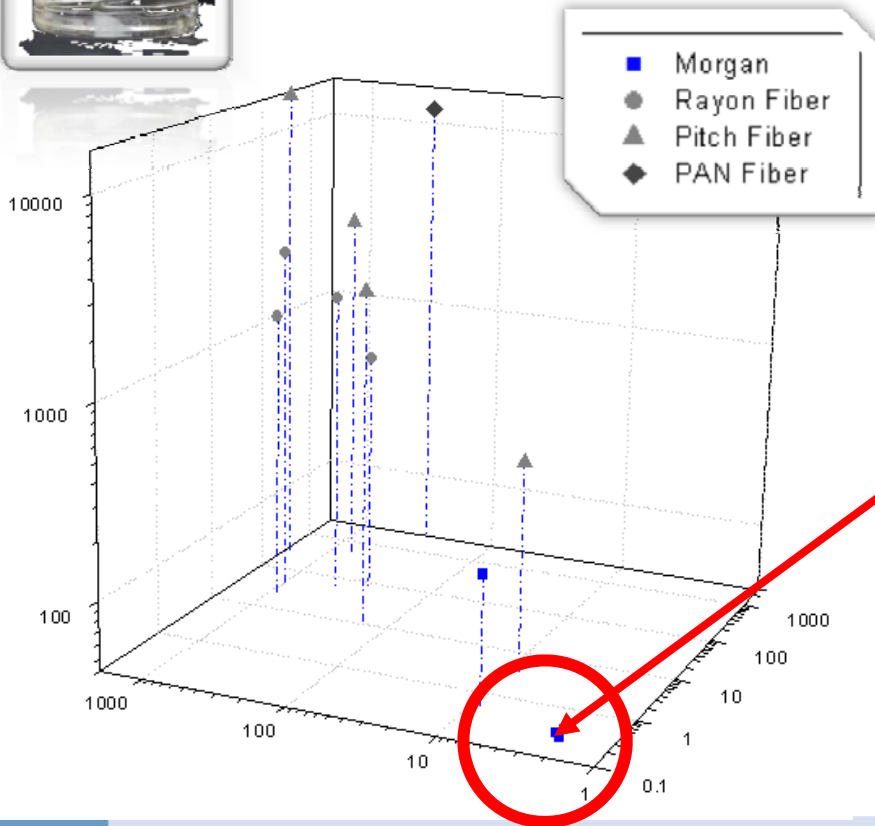
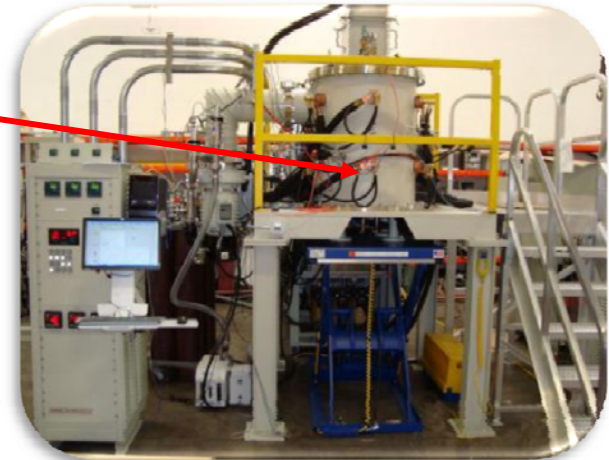

-Typical customer qualification takes 9 months

- Morgan is providing the highest purity LED furnace consumables in the world



- Morgan is selling to more than 40 customers (from a market of over 500)
  - Including major end-users in:
    - » China
    - » Taiwan
    - » Korea
    - » Europe
    - » USA
    - » Japan
  - And ...10 OEMs in the US, Europe and China
- Developing more than 140 customers
- We are well positioned to capitalise on market growth

# Hi-Temp Business

## Industry Drivers

Exploding demand for high efficiency silicon solar cells and white LED's demanding higher performance solutions

## Growth Trends

> 20% CAGR from silicon solar sector and >31% from LED sector

## Megatrends that impact

Renewable energy and energy efficiency

## Target Market

£400m

## Current Market Position

Consumable

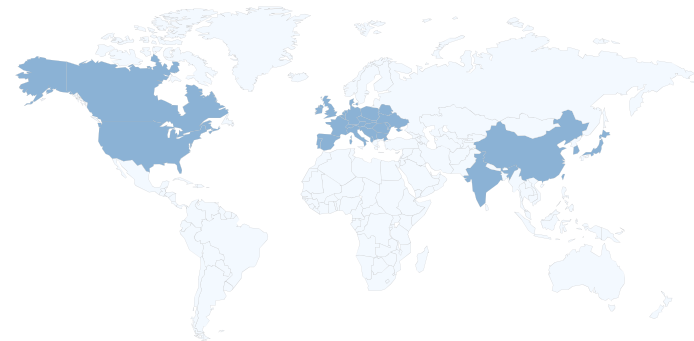
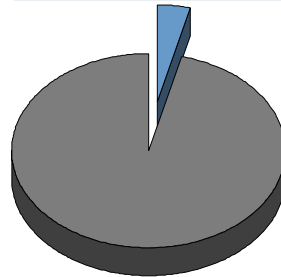

## Strategic Focus:

Leverage Division's global reach and leading edge technology portfolio to capture share and capitalise on market growth – continue to invest in R&D

0% 20% 40% 60% 80% 100%

## Applications



## Products

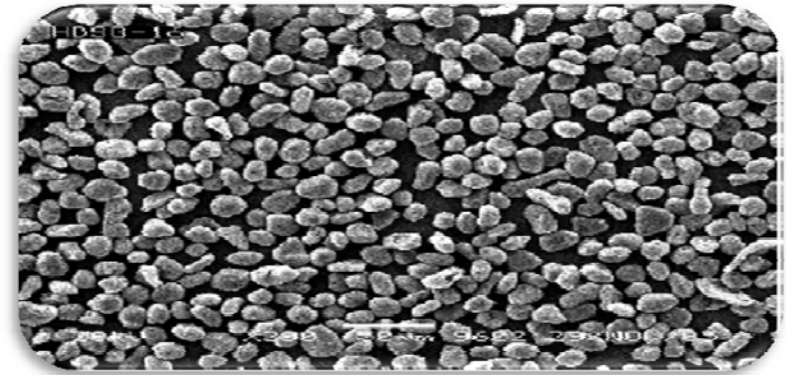

# The Lithium Ion Battery is the 'new engine'

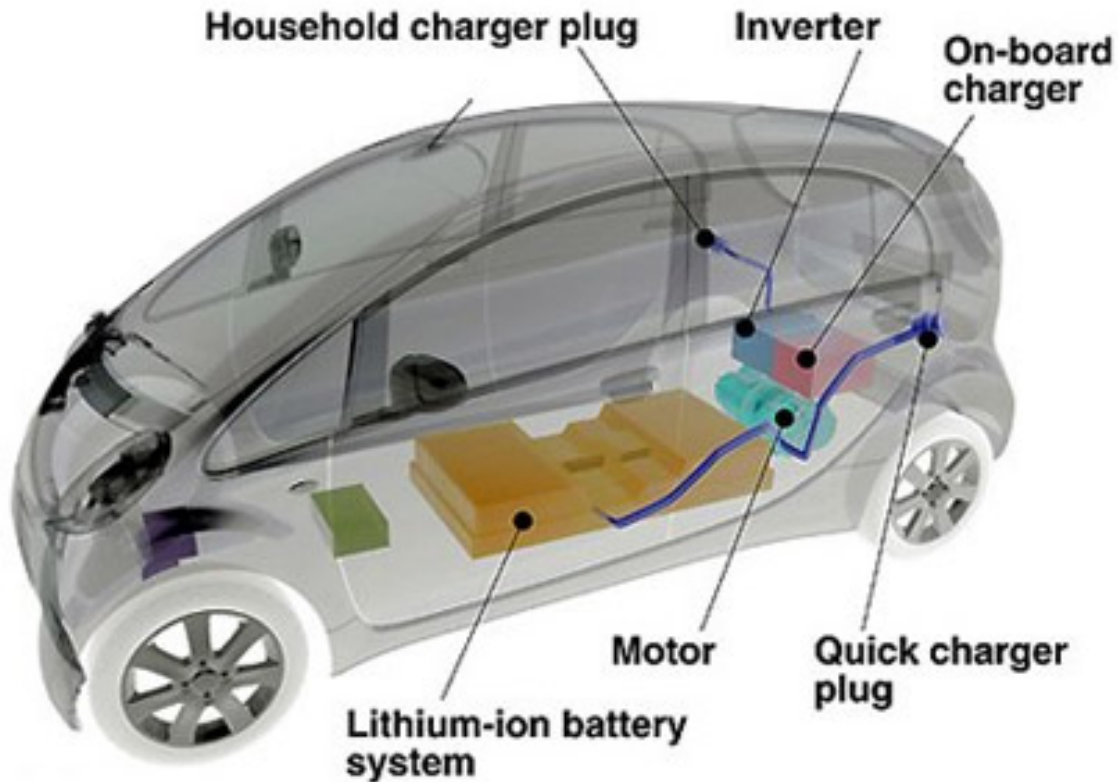

## Anode Active Material

It plays a major role in energy generation and is dominated by carbon based technology

Frost & Sullivan 2010

The performance of the electrodes will govern the performance of the car

# Electric vehicle availability is beginning to grow

## Available today



G-WIZ – range 70 miles



Tesla – range 211 miles



Mitsubishi i-MiEV – range 90 miles



Peugeot iON – range 80 miles



Citroen C-Zero – range 70 miles



Nissan Leaf – range 100 miles

## Available late 2011-2012



Tata EV – range 110 miles



Renault Kangoo – range 105 miles



Smart ForTwo ED – range 85 miles



Vauxhall Ampera – range 50 miles



Renault Twizy – range 60 miles



Renault Fluence – range 100 miles

# Lithium Ion Anode Business

Lithium Ion battery anodes are made from highly engineered graphite powders...

## Market Size LiB Anode materials to 2020

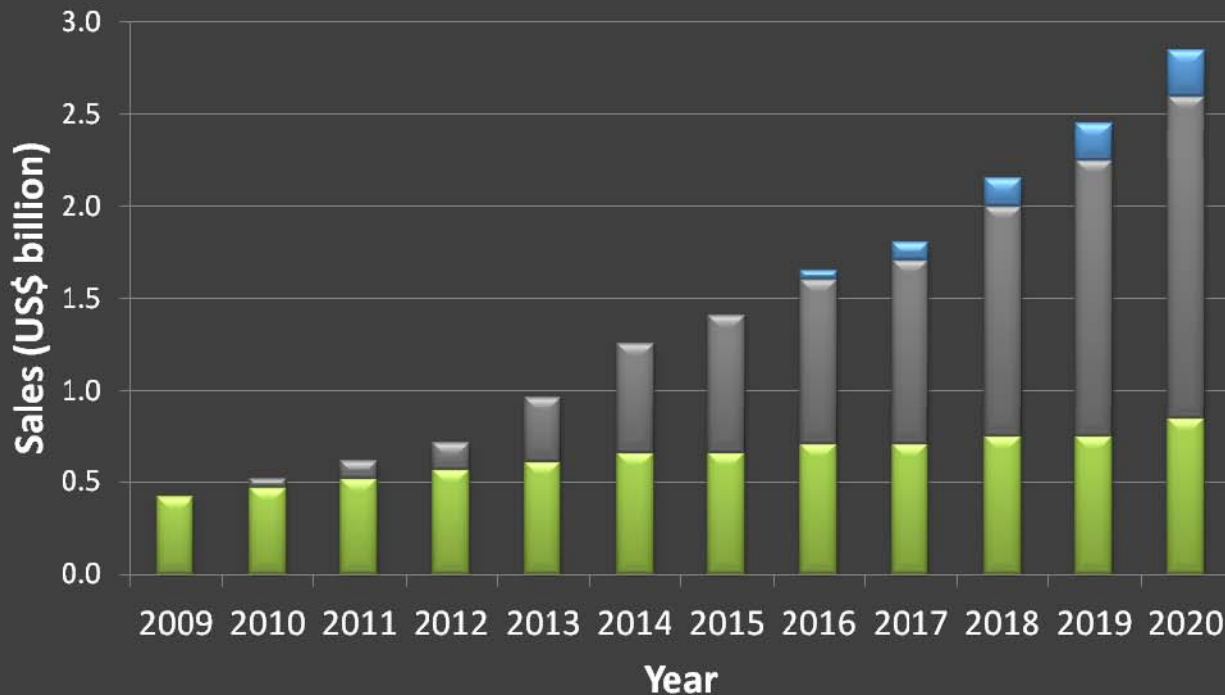

### Utilities



China has already invested \$600M in LiB Energy Storage

### EV



CAGR 126% (2009-2016)  
Frost & Sullivan 2010

### Consumer



Annual growth rate ~15% since 1992

Source: Takeshita

...advanced materials and technology will be enablers for these new applications

## Industry Drivers

Drive for higher and longer power output for portable power, higher charge storage and cyclability for EV and ES

## Growth Trends

Portable power growing at >15% per annum. EV predicted to grow 126% CAGR 2009-2016.

## Megatrends that impact

Declining fossil fuel resource, need to meet International CO2 reduction targets coupled with 'political will' to be leader in EV technology

## Target Market

£375m

## Current Market Position

Consumable

0%

100%

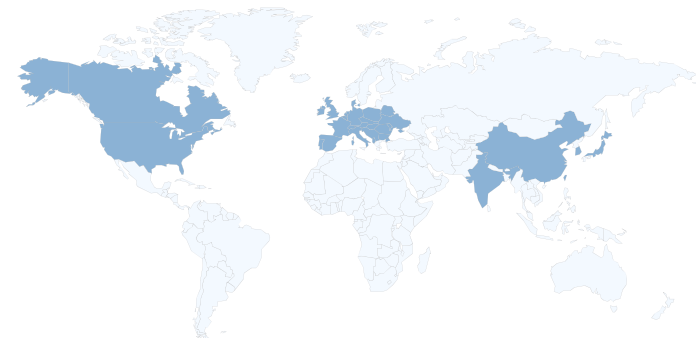
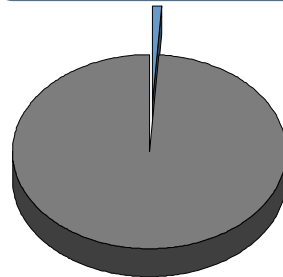

## Strategic Focus:

Link Hairong with Division's infrastructure in China, global reach, and technology centres – continue to invest in R&D and seek alliances/partners

Clean energy business targeted to treble from c.£20 – 60 million of revenue from 2010 to 2013

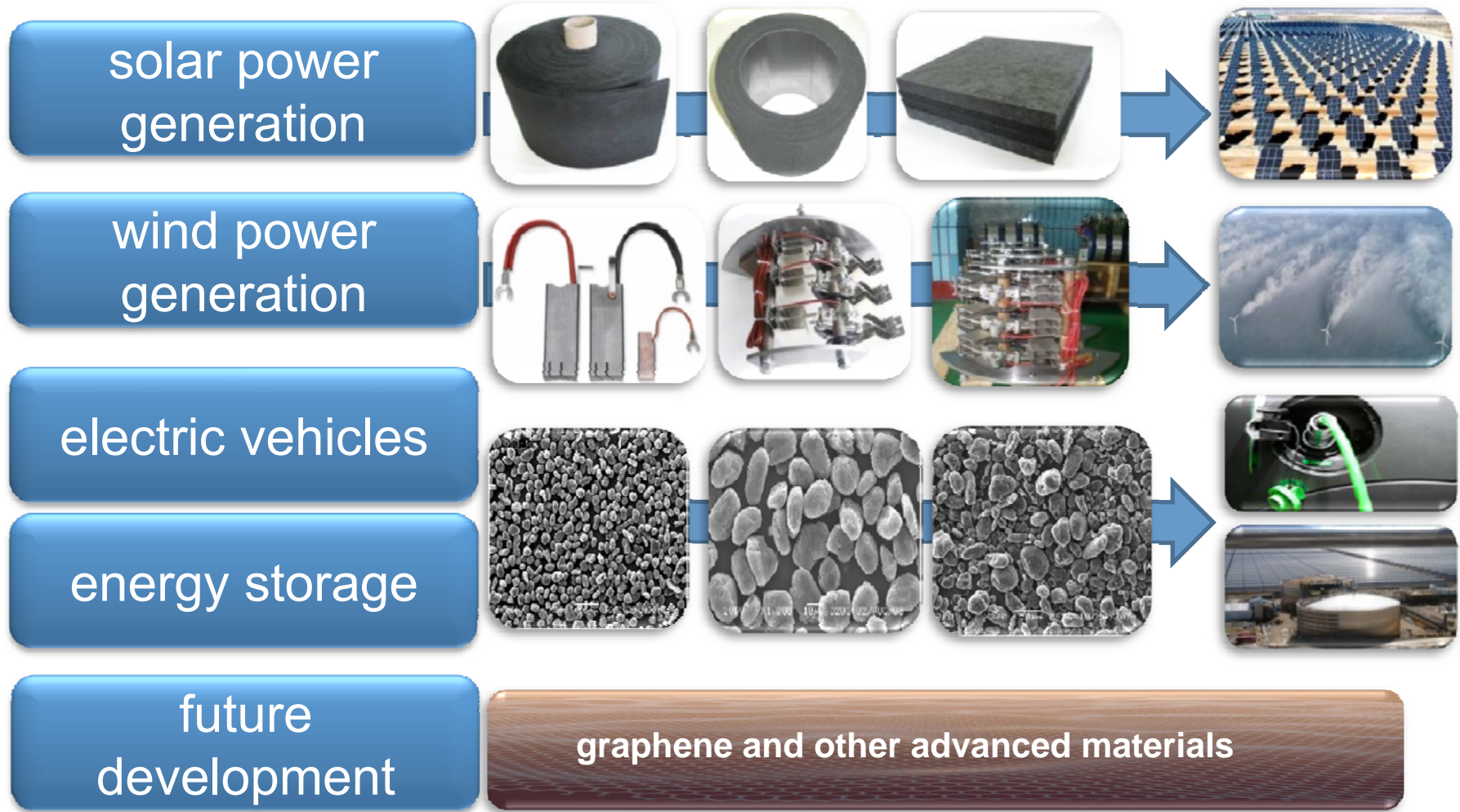



# A technology pipeline filling with exciting prospects for the future in renewable energy

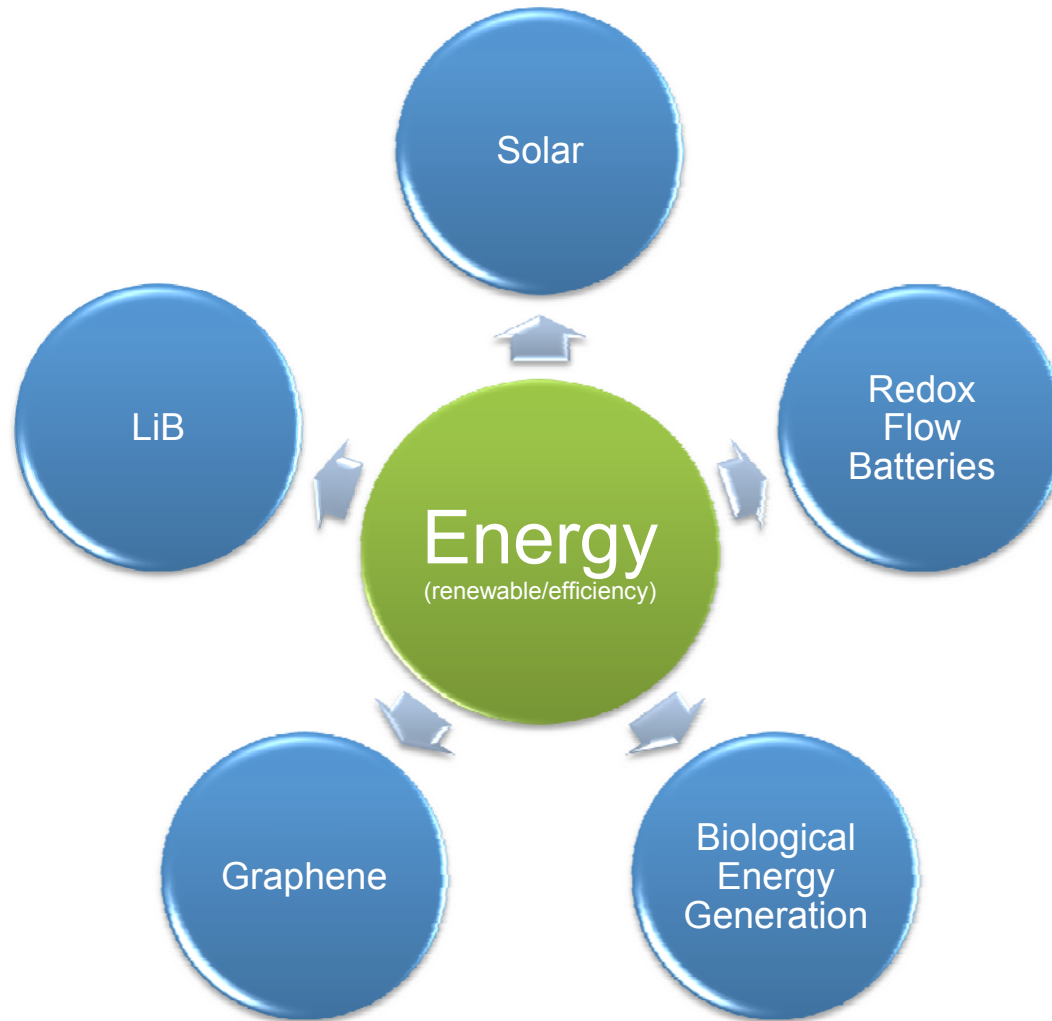

# The Division is well placed to contribute to Morgan's ambition of doubling PBT

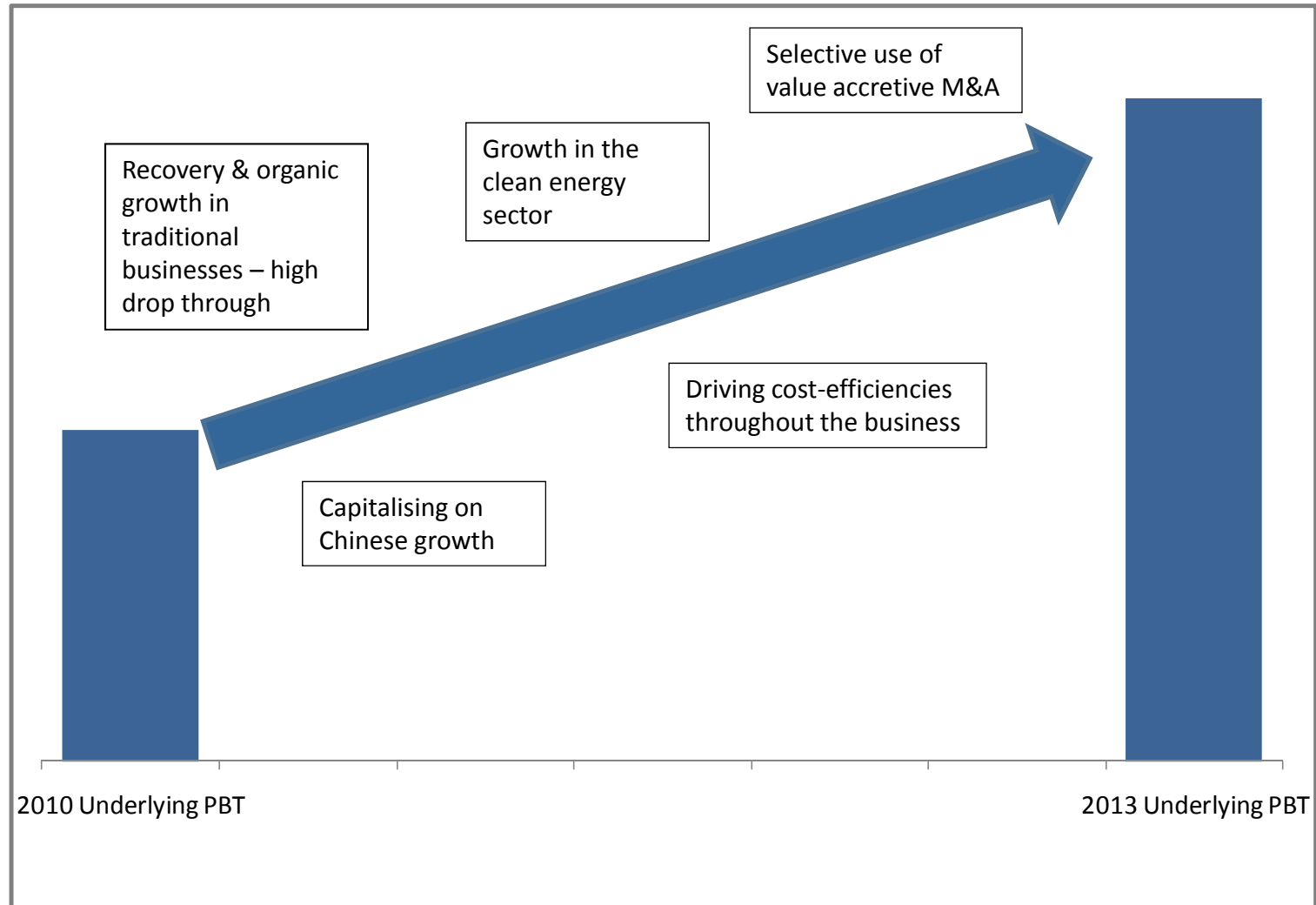

# Key value drivers for 2011 and beyond

	2010 Position	Future Prospects
Extracting GDP or better growth from our base industrial businesses	Ongoing recovery from the 2009 downturn	++
Growth in the clean energy sector	Good progress made in Wind and Solar. Lithium Ion acquisition	+++
Capitalising on Chinese growth	>40% growth seen in 2010. Strong in-country presence	+++
Driving cost-efficiencies throughout the business	34% of divisional direct labour now in low-cost economies	+
Expanding our survivability business internationally	US NP Aerospace office established in Detroit	++
Developing tomorrow's technologies	R&D centres established around the world	++

# CAPITAL MARKETS PRESENTATION 31 MARCH 2011, LONDON

*Engineered Materials Division*

Don Klas

# CAPITAL MARKETS PRESENTATION

## 31 MARCH 2011, LONDON

*Return On Capital Employed (ROCE)*  
&  
*2011 Long Term Incentive Plan (LTIP)*

Kevin Dangerfield

# OPERATING RETURN ON CAPITAL EMPLOYED (OROCE)

# Financial ambitions by 2013

- Double Group underlying PBT\* from £75.7 million to c.£150 million
- Mid-teen underlying operating profit margins
- Improve Operating ROCE from c.25% in 2010 to c.35% by 2013

\*Underlying PBT is defined as operating profit before amortisation, less net financing costs

# Improving Operating Return on Capital (Operating ROCE%)\* in 2010

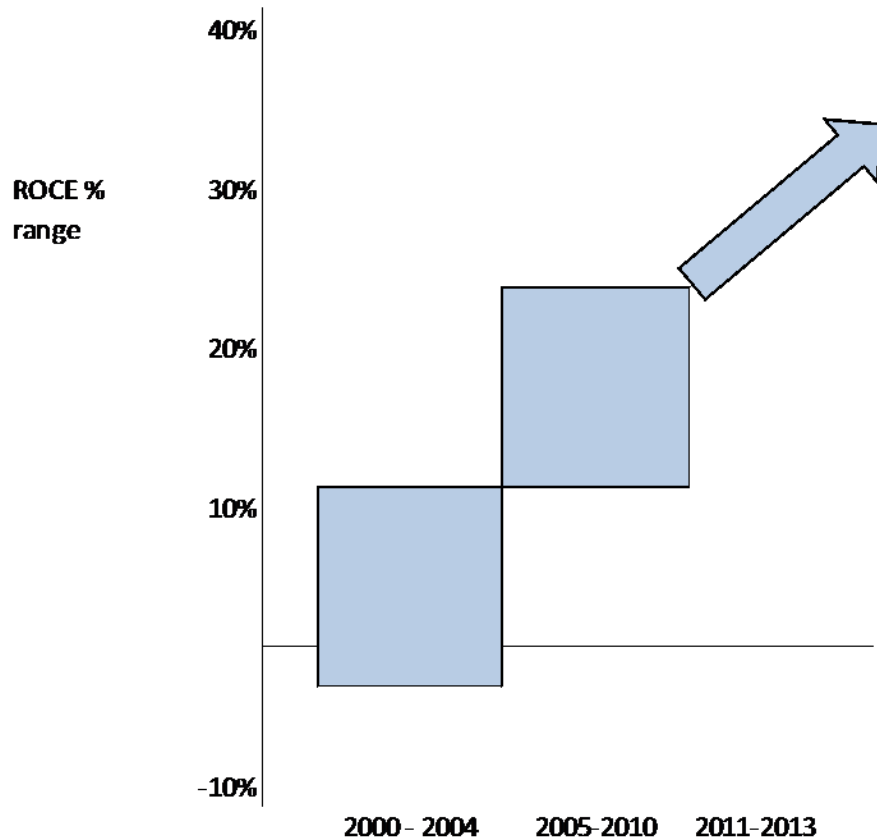

- Pre tax Operating ROCE % in 2010 at 25.4%
- Strong improvement in Operating ROCE% in recent years
- Focus on continued improvement going forward – key element of LTIP plans

\*Return on Operating Capital Employed is defined as Underlying Operating Profit divided by the sum of Working Capital (which excludes pension liability and provisions) and the net book value of tangible assets. Goodwill and other intangible assets are excluded.



# Operating ROCE – managing both working capital and tangible fixed assets

	<b><u>2010 £m</u></b>	
Underlying OP	101.6	
Operating capital employed:		
NBV Land & Buildings	108.8	27%
NBV Plant & Equipment	160.4	40%
Total Working Capital	130.8	33%
	<hr/>	<hr/>
	400.0	100%
Operating ROCE	25.4%	

# Managing low return/low value creation businesses and assets (“Pruning the tail”)

- We want to free up capital and resources tied up in low return businesses and assets to redeploy into much higher return opportunities. Recent examples are:
  - Sale of small, non-core Metal Injection Moulding (MIM) business from New Bedford MTC business to free up capacity for higher return medical ceramics business
  - Sale of MMS French sales and distribution business to a 3<sup>rd</sup> party exclusive distributor
  - Disposal of surplus land (e.g. in the UK, USA and Australia)
- There will be further opportunities to improve asset efficiency – focus at our recent ‘Global Strategy’ conference

# Value accretive M&A – what we are looking for

- Value accretive within the first 12 months
- Complementary and additive technologies with unique points of differentiation
- Access to high growth end-markets and/or high growth end geographies
- Opportunity to leverage Morgan’s global reach
- Operating cost synergies
- “Asset light and knowledge/know how heavy” beats “asset intensive”
- High quality personnel that will have a strong cultural fit with Morgan

# Strong cash generation – ability to invest in bolt-on acquisitions

	FY10	FY09
	£m	£m
Cash from trading *	141.9	120.5
Change in working capital	10.5	25.8
Change in provisions	(4.3)	(11.8)
<b>CASH FLOW FROM OPERATIONS</b>	<b>148.1</b>	<b>134.5</b>
Net capital expenditure	(17.0)	(13.7)
Restructuring costs and other one-off items	(7.8)	(12.1)
Net interest paid	(22.7)	(23.2)
Tax paid	(24.1)	(32.0)
<b>FREE CASH FLOW BEFORE ACQUISITIONS AND DIVIDENDS</b>	<b>76.5</b>	<b>53.5</b>
Cash flows in respect of acquisitions	(32.9)	(31.9)
Dividends paid	(15.4)	(12.1)
Exchange movement and other items	(11.7)	28.2
<b>Movement in net debt in period</b>	<b>16.5</b>	<b>37.7</b>
Opening net debt	(252.7)	(290.4)
<b>Closing net debt</b>	<b>(236.2)</b>	<b>(252.7)</b>

\* Cash from trading is EBITA adjusted for depreciation and loss/profit on sale of plant and machinery

- Morgan is a +£50 million free cash flow business
- Third party working capital to sales ratio below 20%
- Significant acquisition payments
- ...but net debt still reduced £16.5 million year-on-year

# 2011 LONG TERM INCENTIVE PLAN (3 YEAR PLAN) (LTIP)

# 2011 Divisional LTIP's – major improvement from previous metrics to CAGR of OP & ROCE

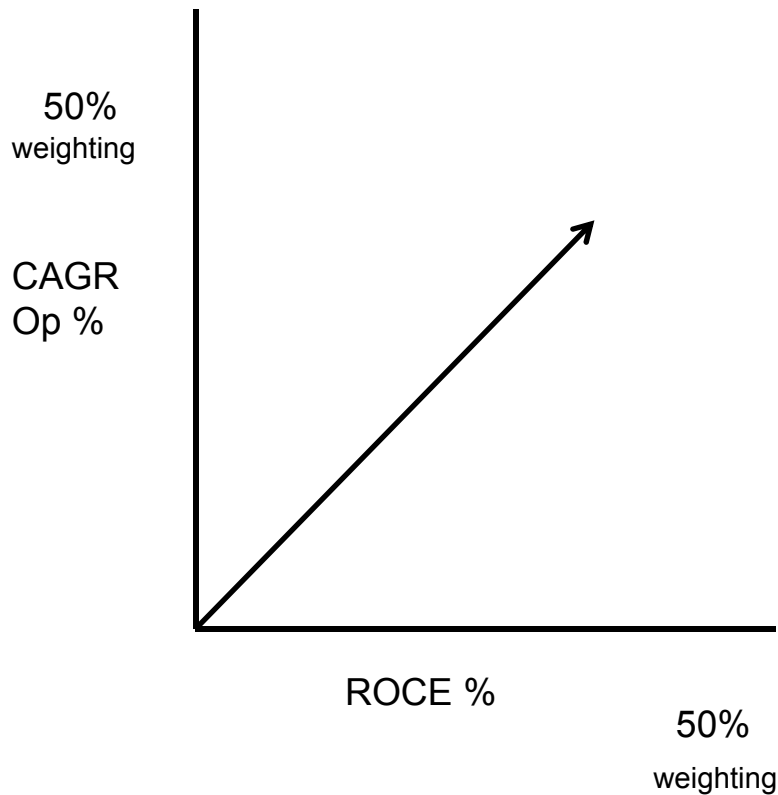

- c100 senior executives below Board level
- Each division has tailored CAGR OP & ROCE targets that underpin Group goals
- CAGR OP/ROCE metrics - equal weighting to both
- Better line of sight for management
- Both metrics within Divisional control - a better incentive scheme than TSR/EPS

# CAPITAL MARKETS PRESENTATION 31 MARCH 2011, LONDON

*Wrap up and Q&A*

Mark Robertshaw

# Our ambition is to double underlying PBT

